



MONTAGE SNOWSOUND CEILING

AKOESTIEKBOETIEK



MOD. 468/ L5







Caimi CAIMI BREVETTI S.p.A.
Via Brodolini 25-27
20834 Nova Milanese (MB) Italy

SNOWSOUND CEILING CABLE FRAME

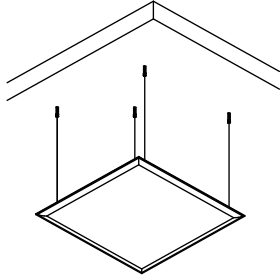
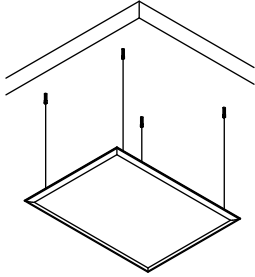
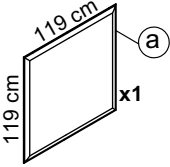
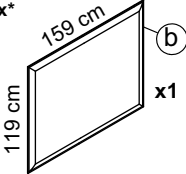
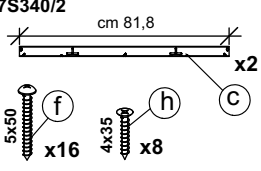
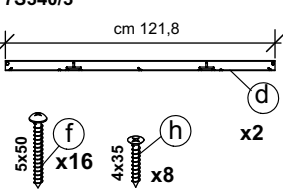
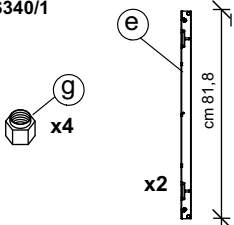
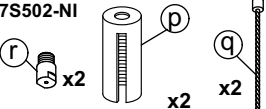
Design:Caimi Lab

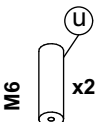
* (xx = variante colore, colour alternative, variante couleur, variante color, Farbe Variante)

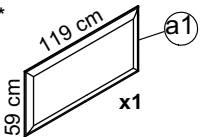
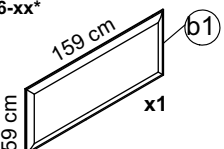
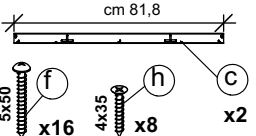
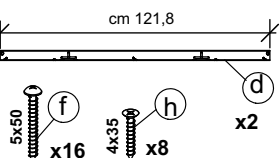
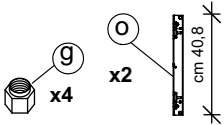
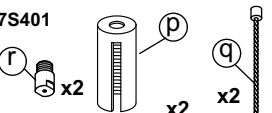
<p>SNOWSOUND</p>	<p>7OSF120</p> 	<p>7OSF160</p> 
<p>7S1212-xx*</p> 	<p>x1</p>	
<p>7S1216-xx*</p> 		<p>x1</p>
<p>7S340/2</p> 	<p>x1</p>	
<p>7S340/3</p> 		<p>x1</p>
<p>7S340/1</p> 	<p>x1</p>	<p>x1</p>
<p>7S502-NI</p> 	<p>x2</p>	<p>x2</p>
<p>7SRM10-C</p> 	<p>x4</p>	<p>x4</p>
<p>7SM6-C OPTIONAL</p> 	<p>x2</p>	<p>x2</p>

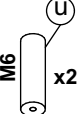
SNOWSOUND	7OSF12060	7OSF16060
	x1	
		x1
<p>7S340/2</p> 	x1	
<p>7S340/3</p> 		x1
<p>7S340/4</p> 	x1	x1
<p>7S401</p> 	x2	x2
<p>7SRM10-C</p> 	x4	x4
<p>7SM6-C OPTIONAL</p> 	x2	x2

cod.7OSF120

1

Posizione telaio sul pannello a
Position frame on Panel a
Positionnez le cadre sur panneau a
Coloque el marco en el Panel a
Standpunkt-Frame auf Panel a

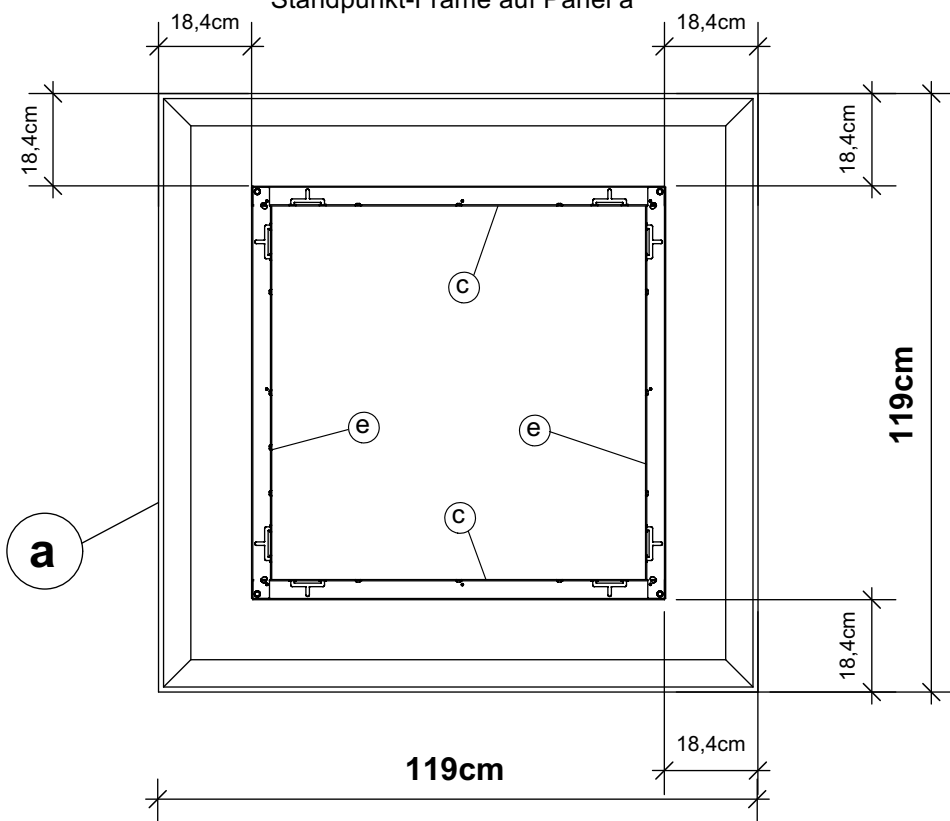
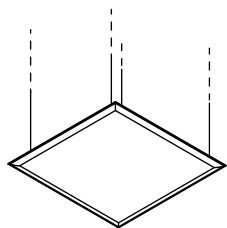

cod.7OSF160

Posizione telaio sul pannello b
Position frame on Panel b
Positionnez le cadre sur panneau b
Coloque el marco en el Panel b
Standpunkt-Frame auf Panel b

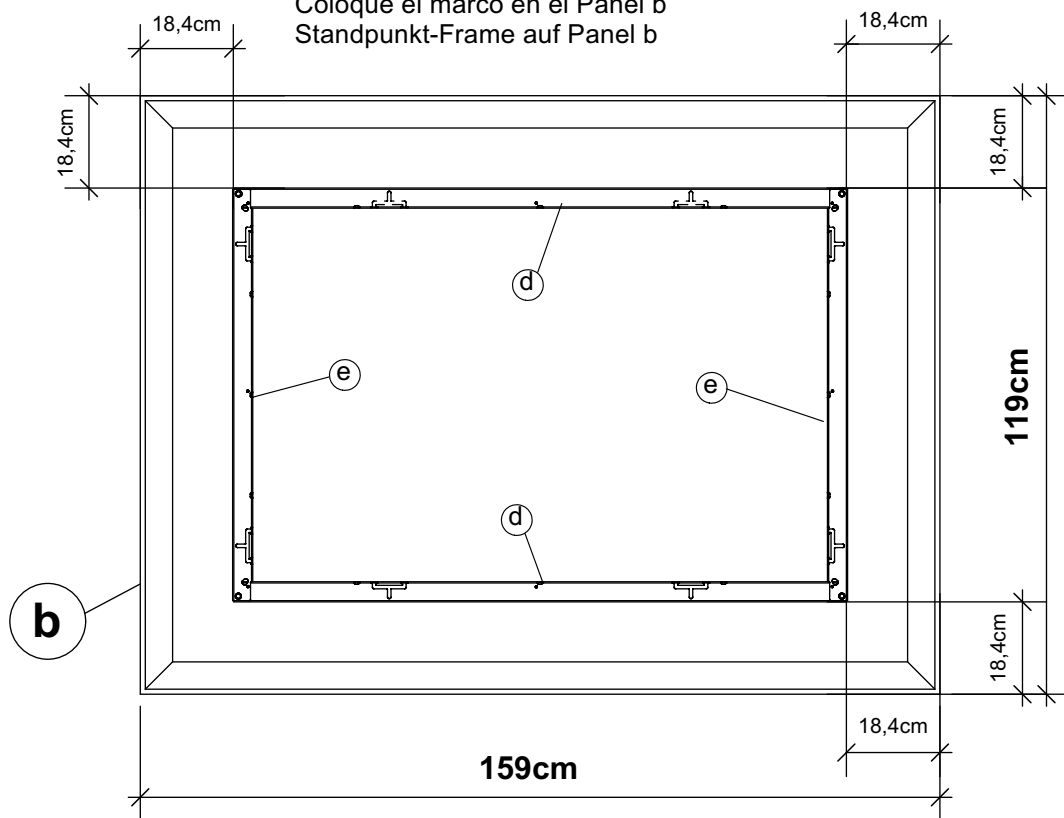
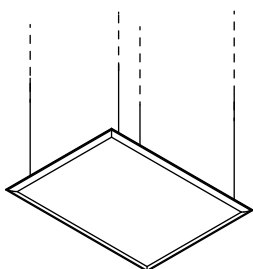

7OSF12060
7OSF16060

Posizione telaio sul pannello a1-b1
Position frame on Panel a1-b1
Positionnez le cadre sur panneau a1-b1
Coloque el marco en el Panel a1-b1
Standpunkt-Frame auf Panel a1-b1

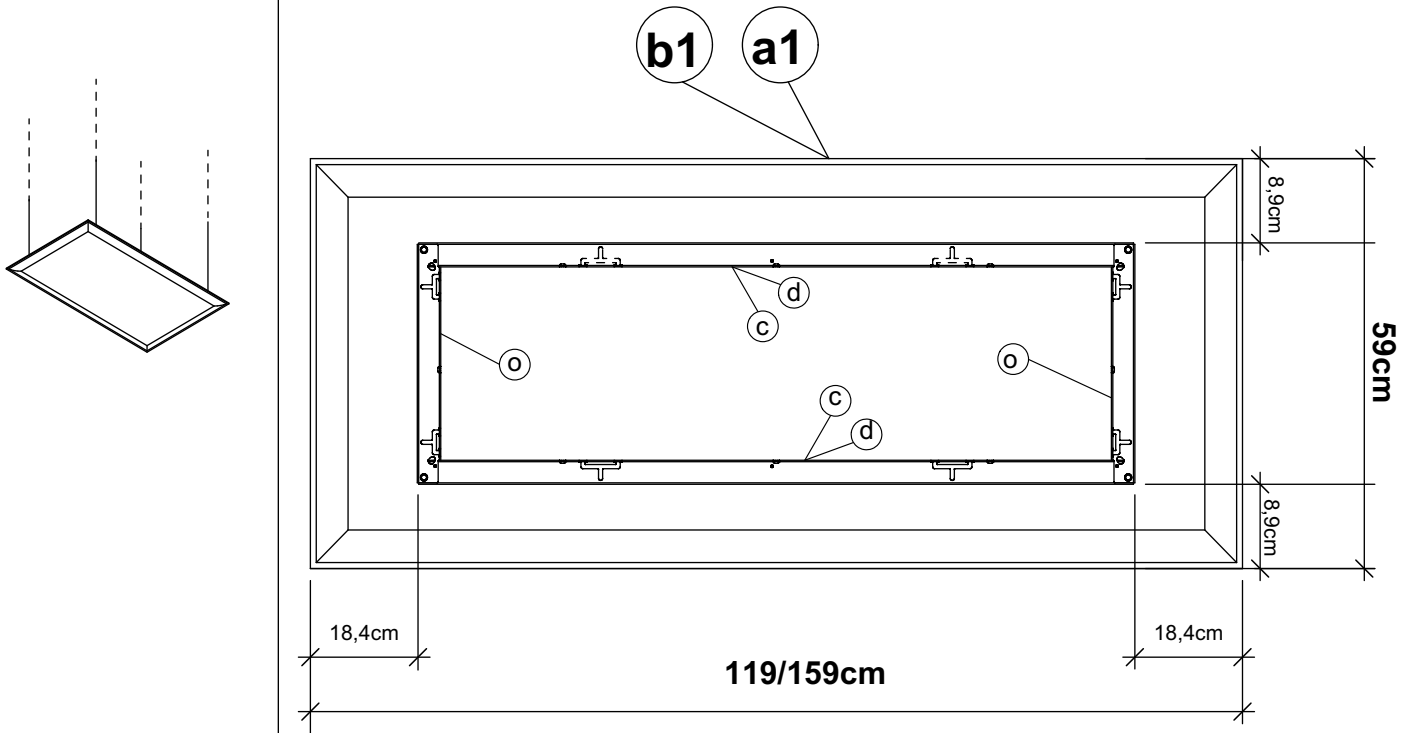

2

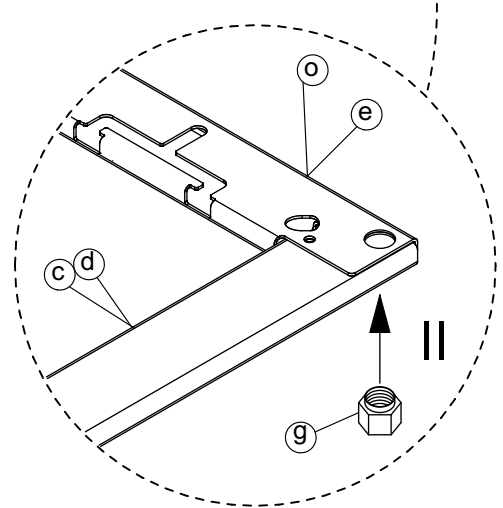
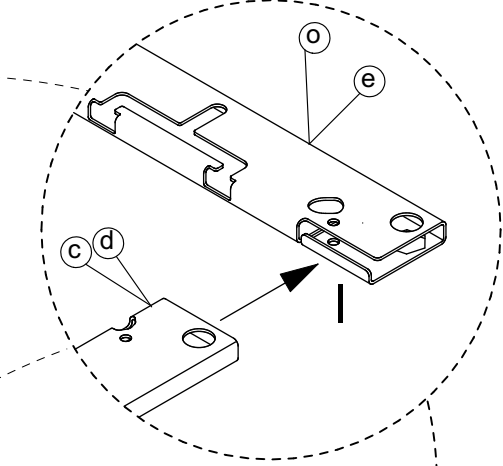
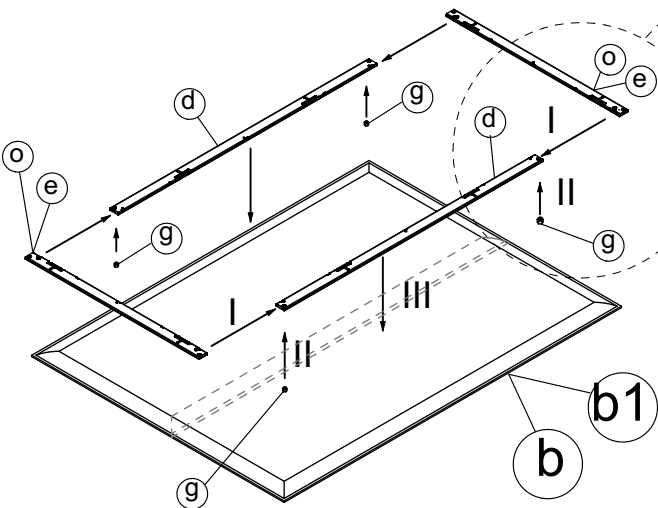
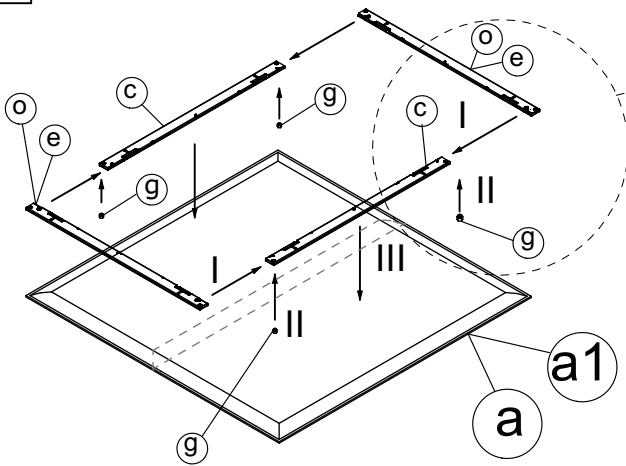

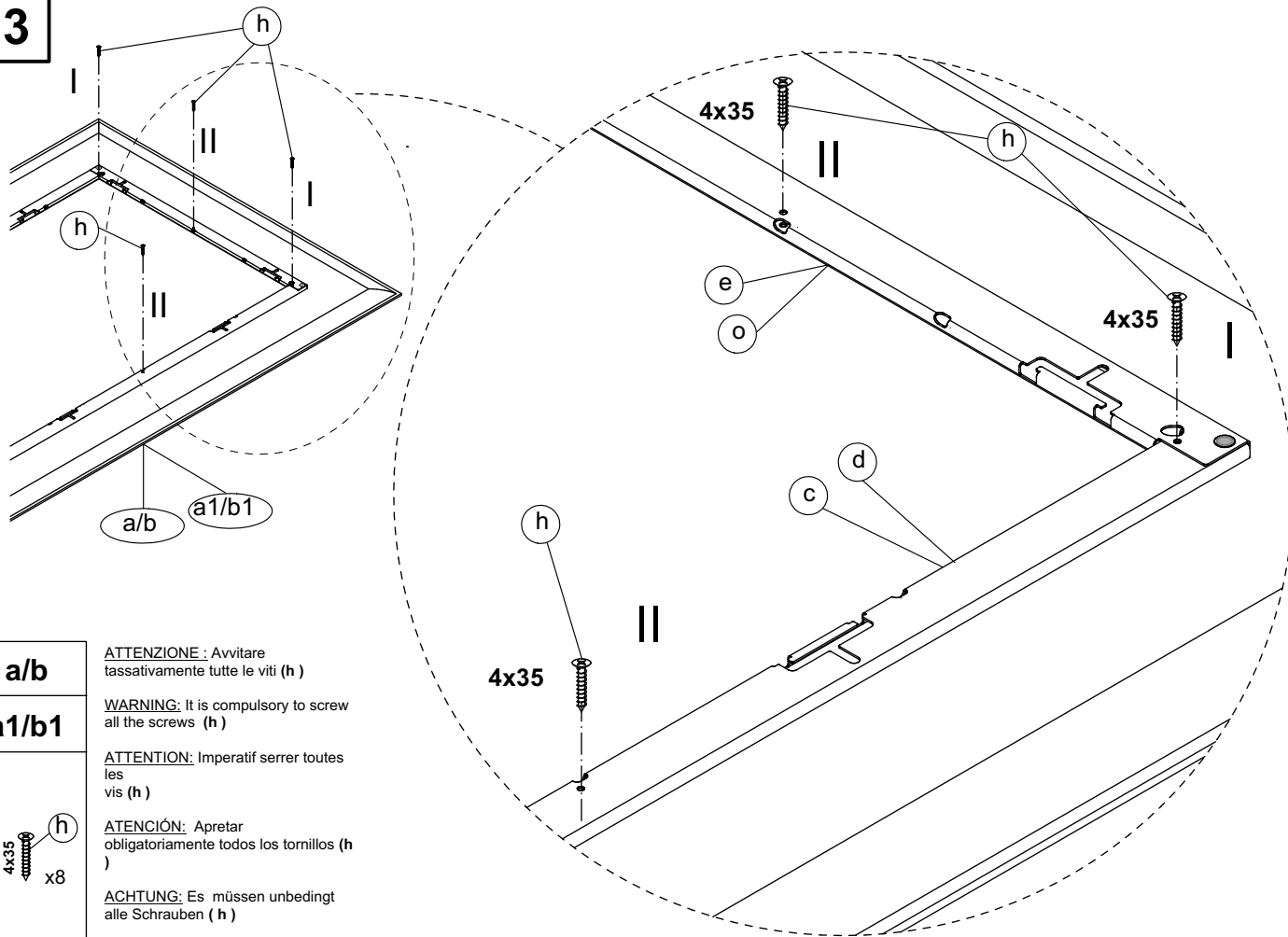
3**a/b**

ATTENZIONE : Avvitare tassativamente tutte le viti (**h**)

a1/b1

WARNING: It is compulsory to screw all the screws (**h**)

ATTENTION: Imperatif serrer toutes les vis (**h**)

ATENCIÓN: Apretar obligatoriamente todos los tornillos (**h**)

ACHTUNG: Es müssen unbedingt alle Schrauben (**h**)

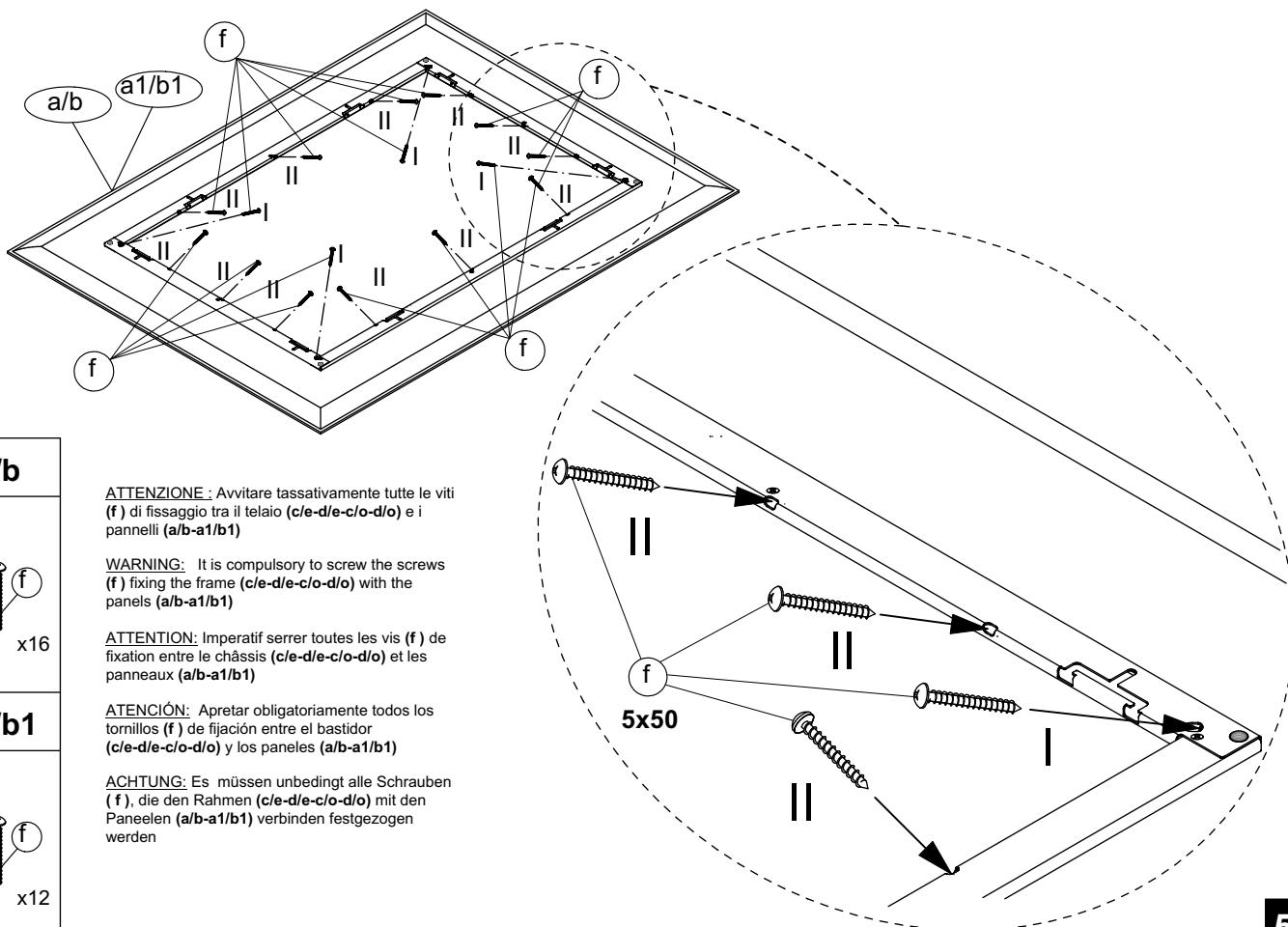
**4****a/b**

ATTENZIONE : Avvitare tassativamente tutte le viti (**f**) di fissaggio tra il telaio (**c/e-d/e-c/o-d/o**) e i pannelli (**a/b-a1/b1**)

WARNING: It is compulsory to screw the screws (**f**) fixing the frame (**c/e-d/e-c/o-d/o**) with the panels (**a/b-a1/b1**)

ATTENTION: Imperatif serrer toutes les vis (**f**) de fixation entre le châssis (**c/e-d/e-c/o-d/o**) et les panneaux (**a/b-a1/b1**)

ATENCIÓN: Apretar obligatoriamente todos los tornillos (**f**) de fijación entre el bastidor (**c/e-d/e-c/o-d/o**) y los paneles (**a/b-a1/b1**)

ACHTUNG: Es müssen unbedingt alle Schrauben (**f**), die den Rahmen (**c/e-d/e-c/o-d/o**) mit den Paneelen (**a/b-a1/b1**) verbinden festgezogen werden

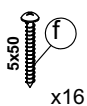
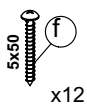
**a1/b1**

5

7OSF120
7OSF12060
7SG12/98-xx*

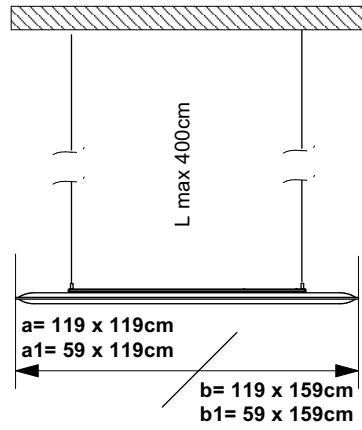
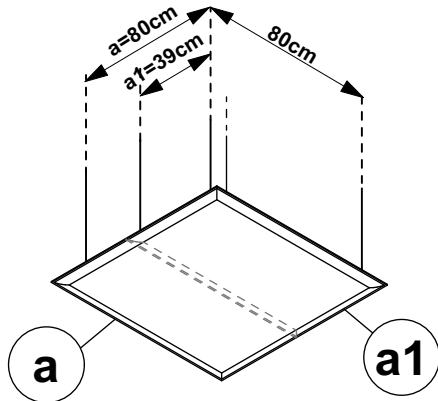

7S502-NI

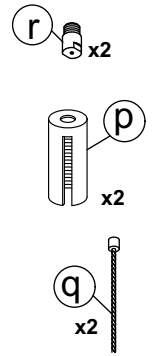

7SRM10-C

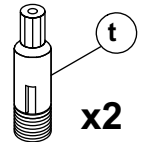

7SM6-C
OPTIONAL

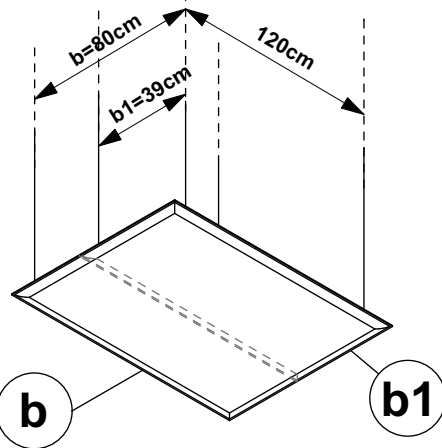
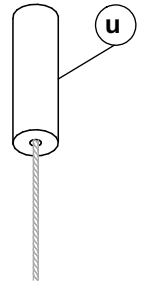

7OSF160
7OSF16060
7SG16/37-0001
7SG16/91-0001

6

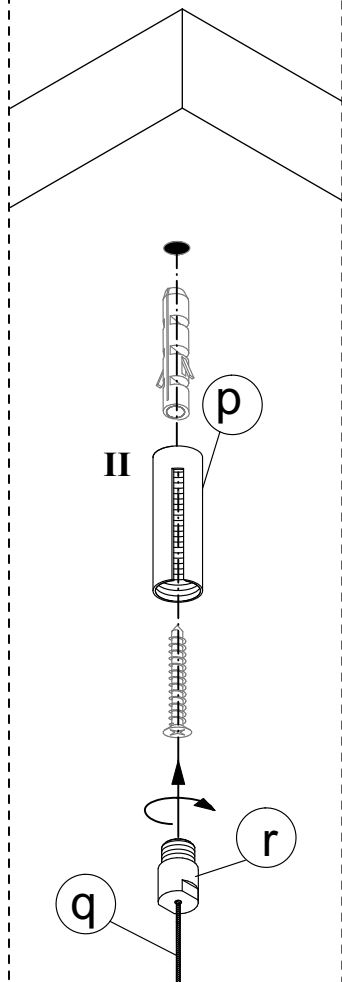
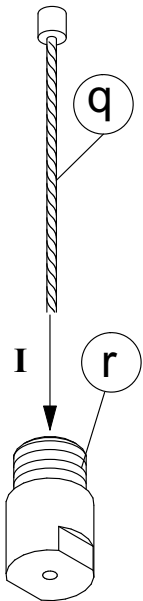

OPTIONAL

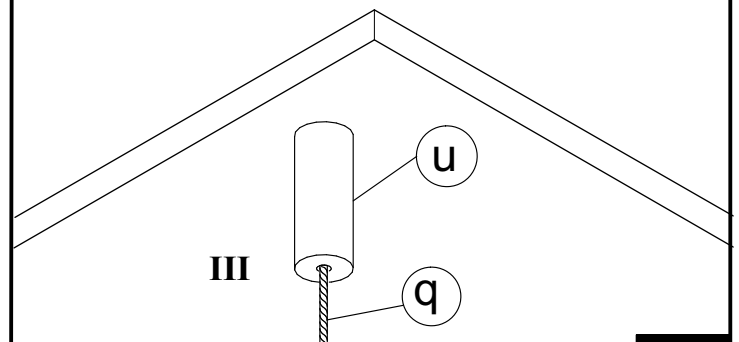
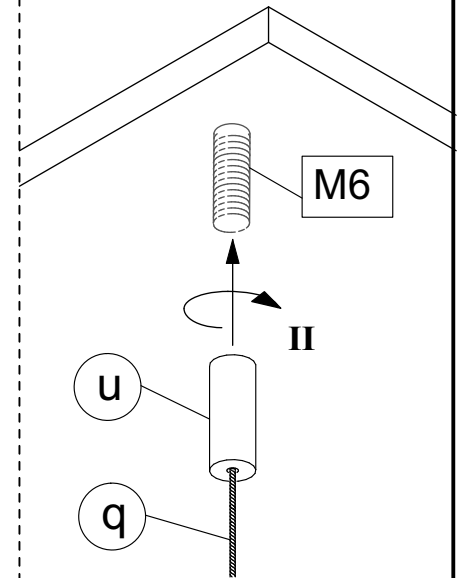
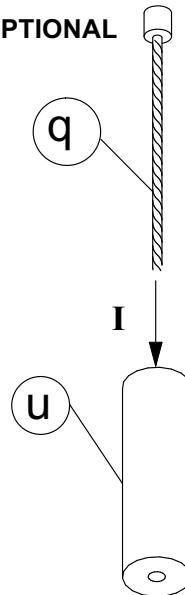

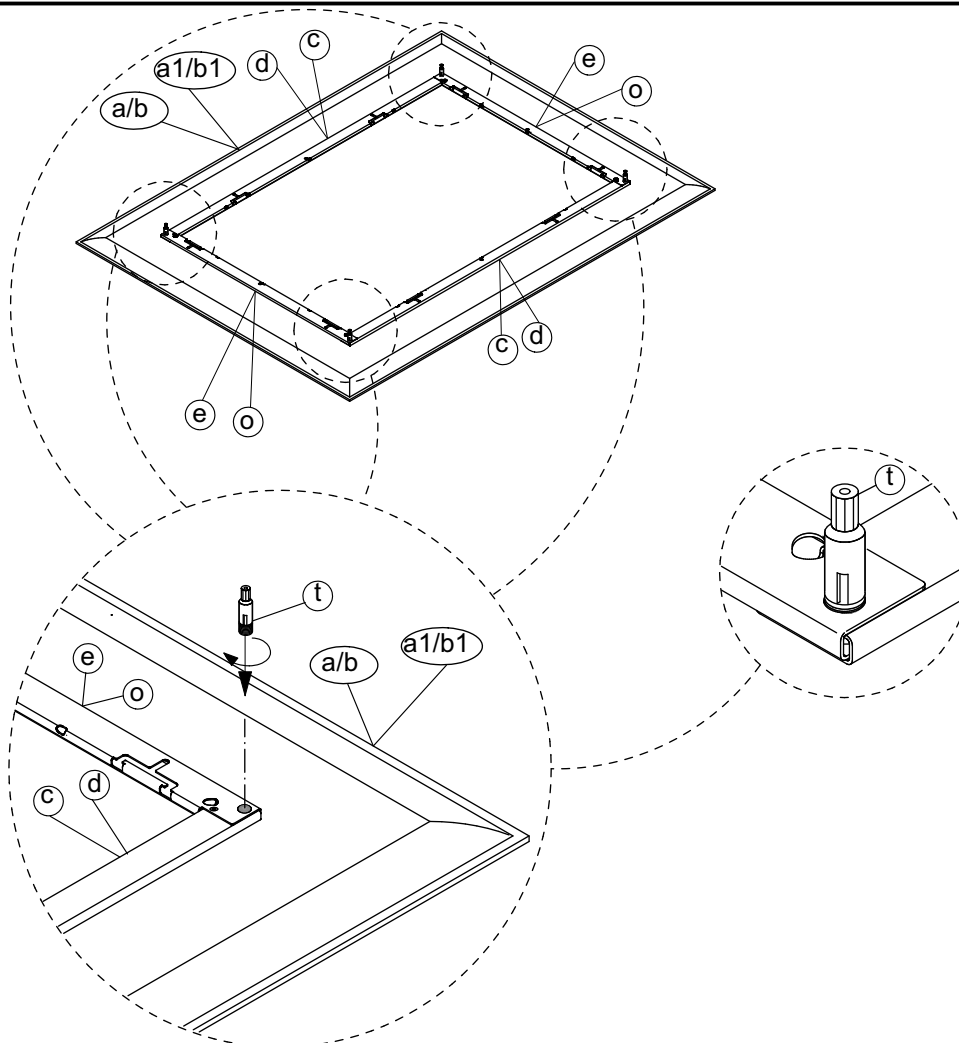

7

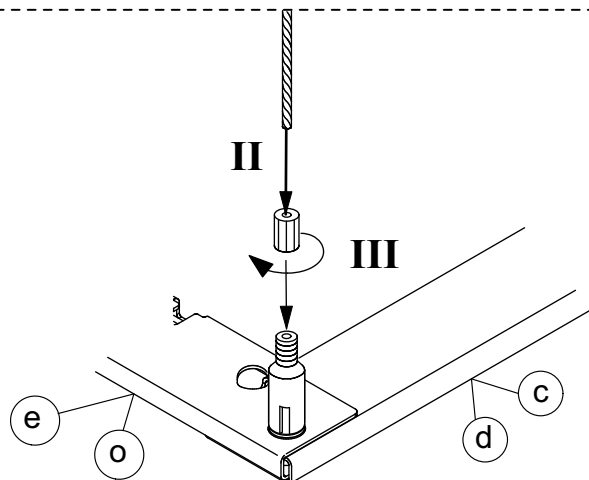
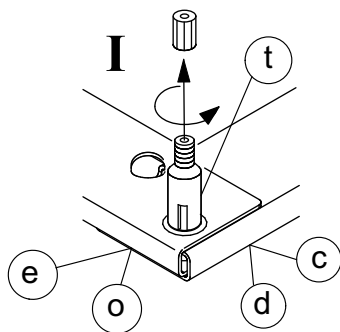

8

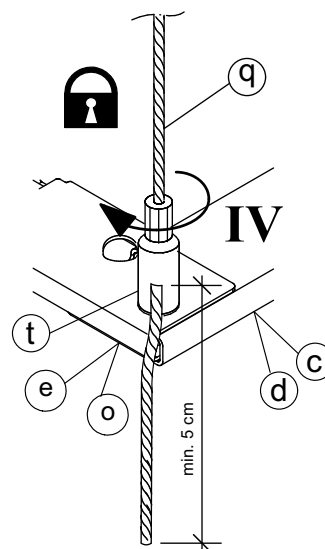
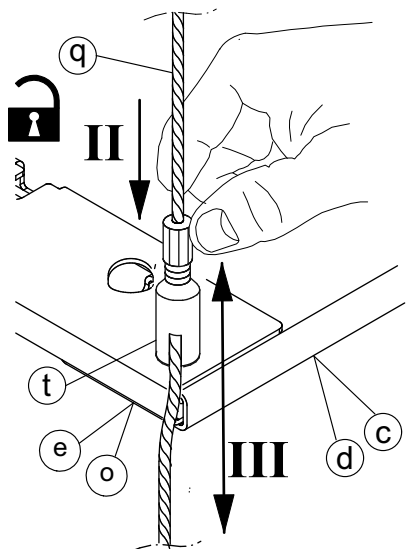

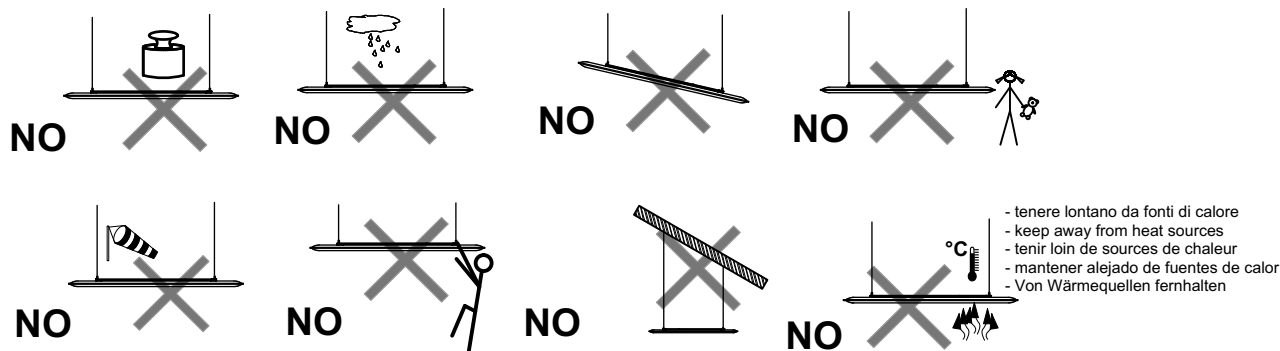
**AVVERTENZE!****ISTRUZIONI ED INFORMAZIONI PER LA SICUREZZA**

prima di procedere al montaggio ed all'installazione del prodotto leggere attentamente le avvertenze di seguito riportate, prestando particolare attenzione ai disegni esplicativi riportati nelle istruzioni per il montaggio. Consultare queste avvertenze ad ogni successivo montaggio e/o installazione del prodotto.

1. Il montaggio e l'installazione del prodotto deve essere effettuato esclusivamente da personale tecnico competente. **Attenzione:** ultimato il montaggio verificare sempre che la struttura realizzata sia idonea al tipo di utenza e/o di utilizzo a cui è destinata. I prodotti non sono comunque idonei all'uso da parte di bambini.
2. Prima di procedere all'installazione è necessario verificare la portanza della superficie su cui verrà collocato il prodotto, di conseguenza utilizzare dispositivi di fissaggio adeguati al tipo di superficie in grado di resistere alle forze generate. **Attenzione:** la superficie deve comunque essere orizzontale, piana, rigida e indeformabile.
3. Attenzione: in caso di dubbi sulle modalità di installazione e/o sulla portanza della superficie su cui verrà collocato il prodotto non procedere alla installazione del prodotto.
4. Per la pulizia del pannello utilizzare esclusivamente un prodotto smacchiatore a secco seguendo attentamente le istruzioni riportate sul prodotto utilizzato.
5. Non utilizzare detersivi per pulire le parti non in tessuto.
6. Per ulteriori informazioni sulle modalità di installazione del prodotto contattare il rivenditore. Per i casi non contemplati contattare il rivenditore.

NOTE!**SAFETY INSTRUCTIONS AND INFORMATION**

Prior to assembling and installing the unit please read the following notes carefully. Pay particular attention to the drawings in the assembly instructions. Please consult these notes every time the product is assembled and/or installed.

1. The product must only be assembled and installed by competent fitters. **Warning:** once the product has been assembled always check that the structure is suitable for the type of application and/or use to which it will be put. These products are not suitable for use by children.
2. Prior to installation check the load bearing capacity of the surface on which the product is to be fitted :use suitable fixtures according to the type of surface which must be able to withstand the forces generated. **Warning:** the surface must be horizontal, flat, rigid and non-deformable
3. **Warning:** if you have any doubts concerning how to install the product and/or the load bearing capacity of the surface on which it will fitted, do not fit it.
4. Do not use detergents to clean the parts that are not in textile fabric.
5. To clean the panel use only a dry stain removal, carefully following the instructions on the product used.
6. For further information on how to install the product, please contact your dealer. For any use different from the ones here shown please contact the dealer.

MISES EN GARDE!**INSTRUCTIONS ET INFORMATIONS DE SÉCURITÉ**

Avant de procéder au montage et à l'installation du produit, lire attentivement les mises en garde ci-dessous présentées, en faisant particulièrement attention aux dessins explicatifs rapportées dans les instructions de montage. Consulter ces mises en garde lors de chaque montage successif et/ou installation du produit.

1. Le montage et l'installation du produit doivent exclusivement être effectués par un personnel technique compétent. **Attention:** au terme du montage, toujours vérifier si la structure réalisée est appropriée au type d'usagers et/ou d'utilisation auxquels elle est destinée. Les produits ne sont pas destinés aux enfants.
2. Avant de procéder à l'installation, il est nécessaire de vérifier la capacité de charge de la surface sur laquelle le produit sera installé : en conséquence, utiliser les dispositifs de fixation adaptés au type de surface et qui peuvent résister aux forces produites. **Attention :** la surface doit être horizontale, plane, rigide et indeformable.
3. **Attention:** en cas de doute sur les modalités d'installation et/ou sur la capacité de charge de la surface sur laquelle le produit sera installé, ne pas monter le produit.
4. Pour le nettoyage du panneau utiliser seulement un détachant à sec en suivant soigneusement les instructions sur le produit utilisé.
5. Ne pas utiliser de détergents pour nettoyer les pièces qui ne sont pas en tissu.
6. Pour toute information complémentaire sur les modalités d'installation, contacter le revendeur. Pour emploi différent par rapport à ceux indiqués ici nous vous prions de contacter le revendeur.

¡ADVERTENCIAS!**INSTRUCCIONES E INFORMACIÓN DE SEGURIDAD**

Antes de realizar el montaje y la instalación del producto leer atentamente las advertencias que se indican a continuación, prestando especial atención a los dibujos y a las instrucciones para el montaje. Consultar estas advertencias cada vez que se monte y/o instale el producto.

1. El montaje y la instalación del producto debe efectuarlo exclusivamente personal técnico competente. **Atención:** una vez acabado el montaje, hay que comprobar siempre que la estructura realizada sea apta para el tipo de servicio y/o uso al que se va a destinar. Los productos no son aptos para niños.
2. Antes de realizar la instalación es necesario controlar la capacidad de carga de la superficie en la que se colocará el producto :por consiguiente, hay que utilizar dispositivos de fijación adecuados para el tipo de superficie capaces de resistir las fuerzas generadas. **Atención:** la superficie del suelo debe en cualquier caso ser horizontal, plana, rígida e indeformable.
3. **Atención:** en caso de duda sobre las modalidades de instalación y/o sobre la capacidad de carga de la superficie en la que se vaya a colocar el producto, éste no deberá instalarse.
4. Para la limpieza del panel utilizar exclusivamente un producto quitamanchas seco, siguiendo atentamente las instrucciones que aparecen sobre el producto utilizado
5. No utilizar detergentes para las partes que no son tejidos.
6. Para más información sobre las modalidades de instalación del producto, ponerse en contacto con el vendedor. Para cualquier otra utilización por favor consulte con su distribuidor.

WICHTIG!**SICHERHEITSHINWEISE UND INFORMATIONEN**

Vor der Montage und der Aufstellung des Produktes folgende Anleitungen sorgfältig lesen und dabei die Einbauezeichnungen, die in den Montageanleitungen zu finden sind, genau beachten. Die vorliegenden Anweisungen bei jeglicher späteren Montage und/oder Aufstellung des Produktes nachsehen.

1. Die Montage und die Aufstellung des Produktes dürfen ausschließlich von erfahrenem Fachpersonal ausgeführt werden. **Vorsicht:** sich nach der Montage immer vergewissern, dass die aufgestellte Struktur ihren Verwendungszwecken und/oder dem Benutzerkreis entspricht. Es ist aber dabei nicht zu vergessen, daß der Gebrauch dieser Produkte Kindern untersagt ist.
2. Vor jeglicher Montage die Oberfläche, an der das Produkt montiert werden soll, auf ihre Tragfähigkeit prüfen und passende Befestigungsmittel welche die erzeugten Kräfte aushalten können je nach Art der Oberfläche benutzen. **Vorsicht:** die Bodenfläche immer waagrecht, flach, steif und unverformbar sein.
3. **Wichtig:** bestehen Zweifel über die Einbaumodalitäten und /oder über die Tragfähigkeit der betroffenen Oberfläche, Produkt nicht aufstellen.
4. Zur Reinigung der Akustikpaneele darf nur Schaumreiniger verwendet werden, wobei die Anleitung auf dem gewählten Produkt genau zu befolgen ist.
5. Für die Reinigung der nicht aus Textilgewebe bestehen Teile keine Reinigungsmittel verwenden.
6. Für weitere Angaben über die Aufstellungsmodalitäten wenden Sie sich bitte an Ihren Wiederverkäufer. Für alle Anlagen, die nicht aufgeführt sind, kontaktieren Sie bitte vor dem Einbau den Fachhandel



AKOESTIEKBOETIEK



Deze informatie is afkomstig van de website van AkoestiekBoetiek.nl.

Voor vragen, toelichting en meer informatie kunt u contact opnemen met:

AkoestiekBoetiek

Modem 20b

7741 MJ Coevorden

T +31 (0)85-077 3688

E info@akoestiekboetiek.nl

W www.akoestiekboetiek.nl