



MONTAGE OVERSIZE LUX

AKOESTIEKBOETIEK



MOD. 496/ L1



8 002447 294327

Caimi
BREVETTI

OVERSIZE LUX

Design: Caimi Lab

* (xx = variante colore, colour alternative, variante couleur, variante color, Farbe Variante)

cod.7OL1212/1F-xx*

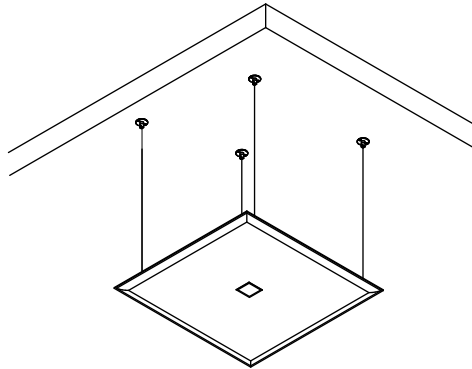

cod.7OL1216/2F-xx*

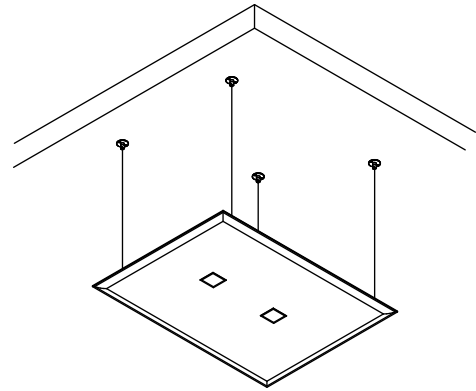

**ISTRUZIONI DI MONTAGGIO
ASSEMBLY INSTRUCTIONS
NOTICE DE MONTAGE
INSTRUCCIONES DE MONTAJE
MONTAGEANLEITUNG**

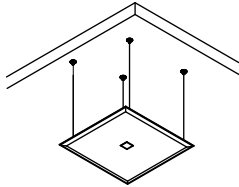
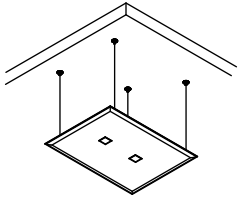
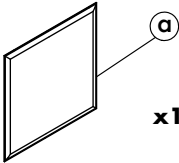
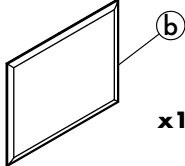
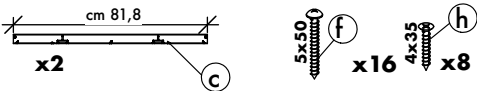
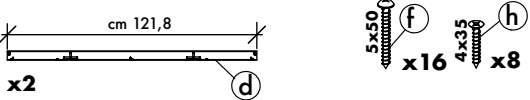
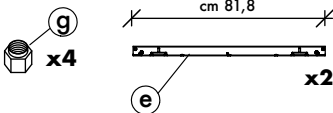
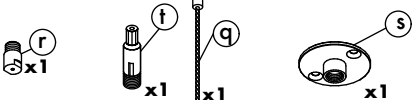
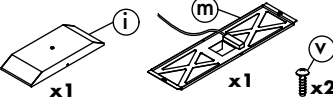
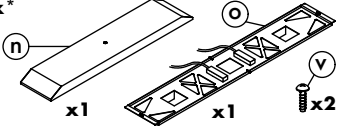
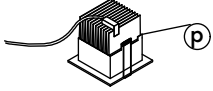
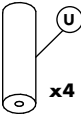
	7OL1212/1F-xx*	7OL1216/2F-xx*	
			
7S1212/1F-xx*	 x1	x1	
7S1216/2F-xx*	 x1	x1	
7S340/2	 x2	x1	
7S340/3	 x2	x1	
7S340/1	 x4 x2	x1	x1
7S401	 x1 x1 x1 x1	x4	x4
7S1F120-xx*	 x1 x1 x2	x1	
7S2F160-xx*	 x1 x1 x2		x1
7S1F	 x1	x1	x2
7SM6-C OPTIONAL	 x4	OPTIONAL	OPTIONAL

7SL/RD7-xx*
OPTIONAL

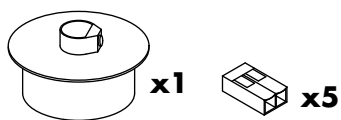

ATTENZIONE: per l'installazione vedere attentamente le istruzioni allegate al corpo illuminante

ATTENTION: for the installation carefully read the instructions attached to the lighting element

ATTENTION: Pour l'installation lisez attentivement les instructions jointes aux l'élément d'éclairage

ATENCIÓN: Para la instalación lea cuidadosamente las instrucciones adjuntas all' elemento de iluminación

ACHTUNG: Für die Installation lesen Sie bitte sorgfältig die Anweisungen im Scheinwerfer

7OL1212/1F-xx*

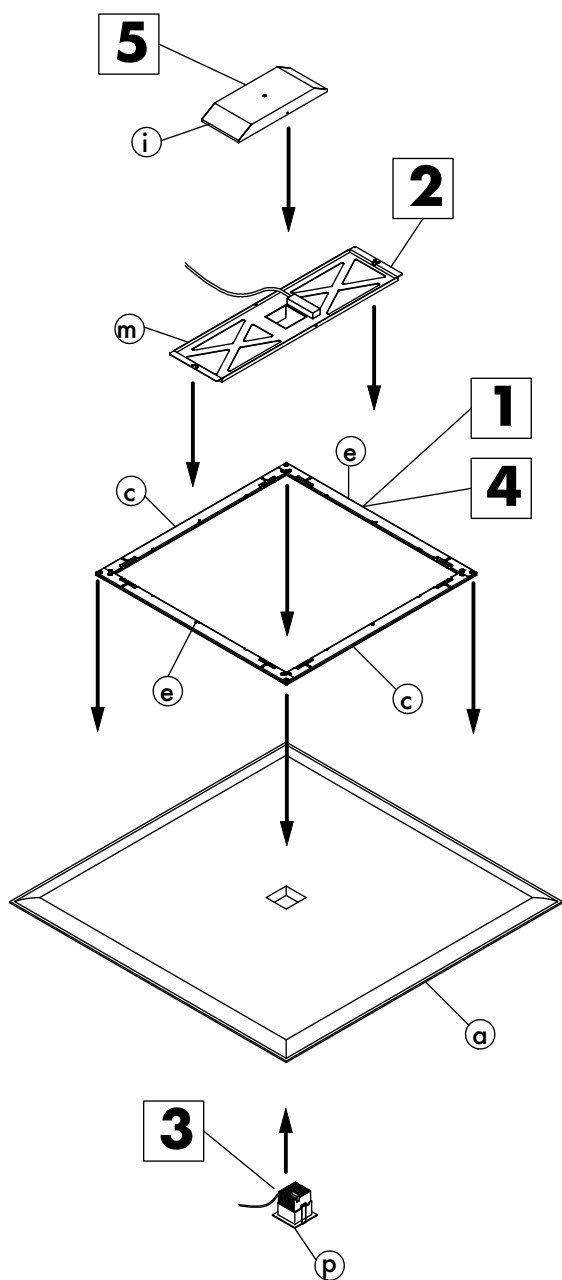

7OL1216/2F-xx*

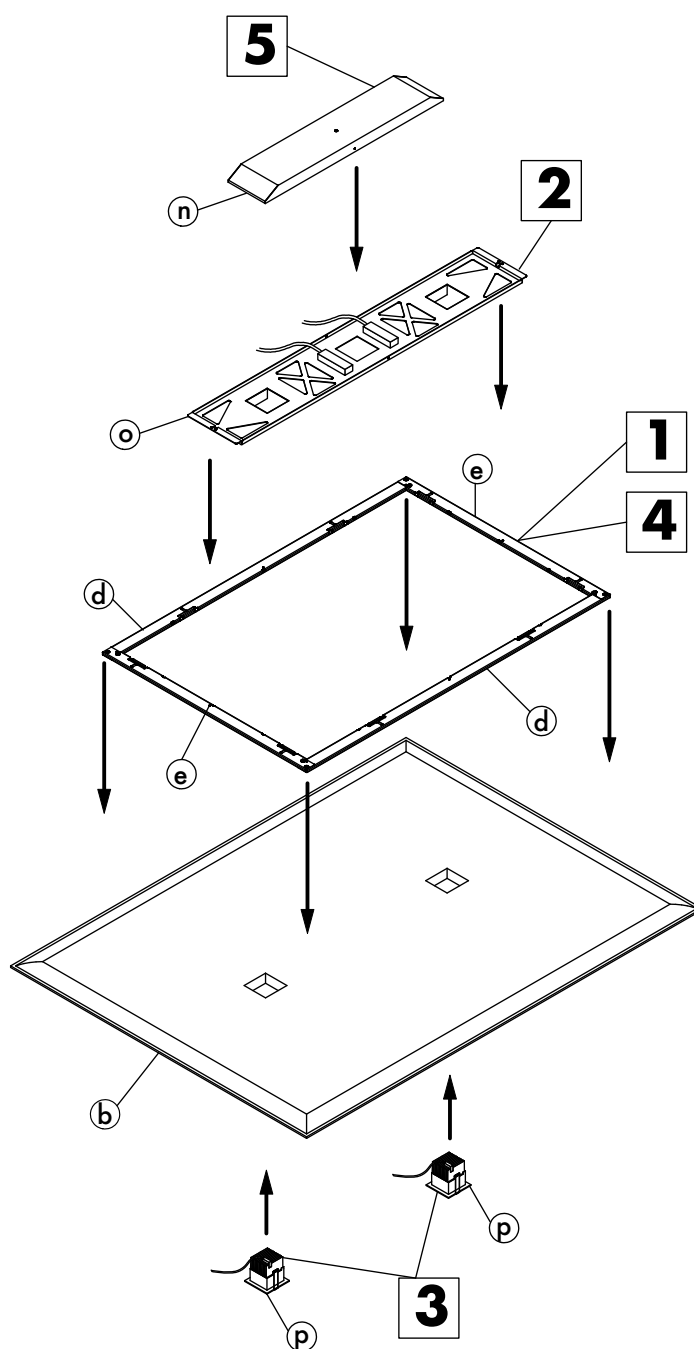

- Posizionare telaio sul pannello senza fissarlo
- Position frame on Panel without fixing it
- Positionnez le cadre sur panneau sans fixation
- Coloque el marco en el Panel sin fijarlo
- Standpunkt-Frame auf Panel ohne Fixierung

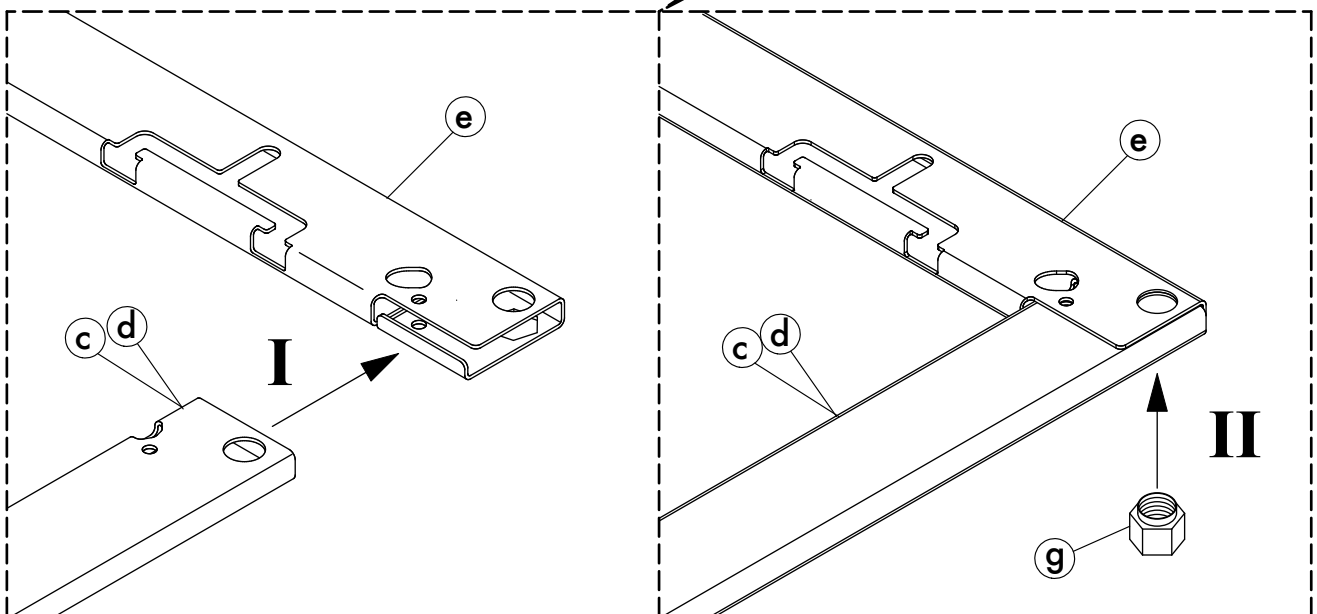
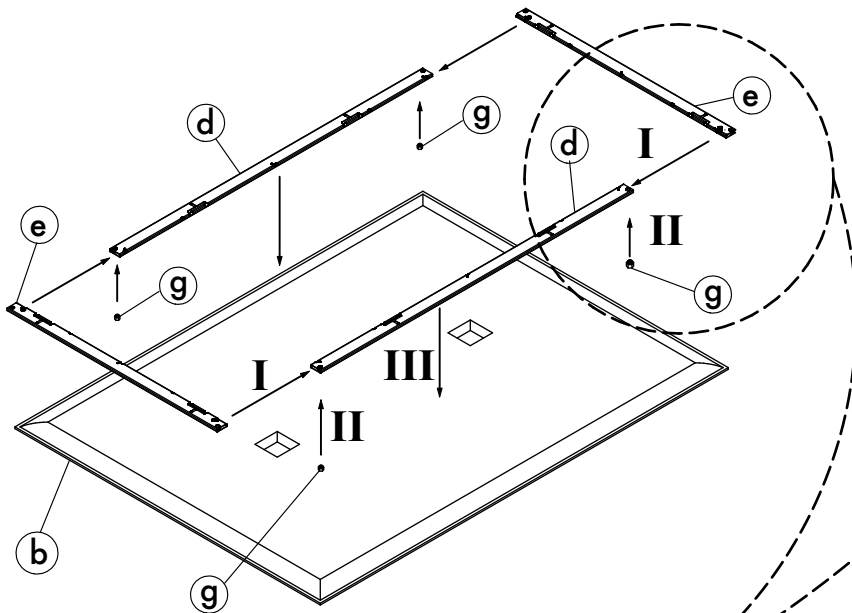
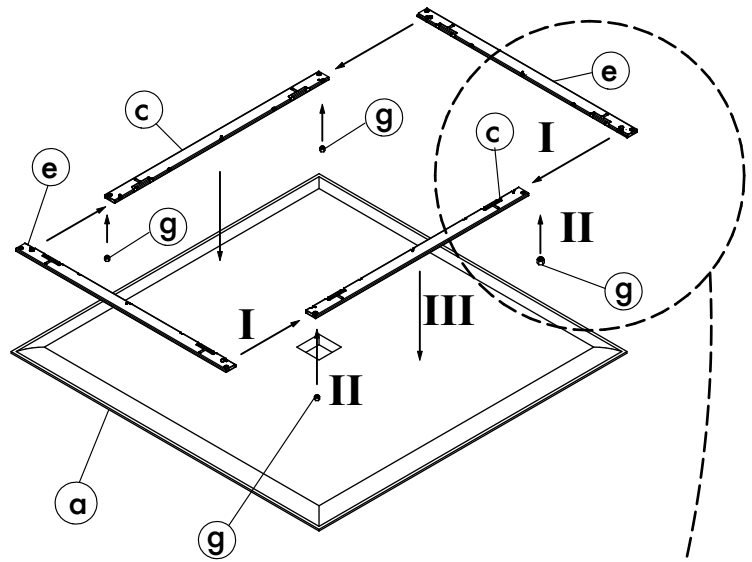

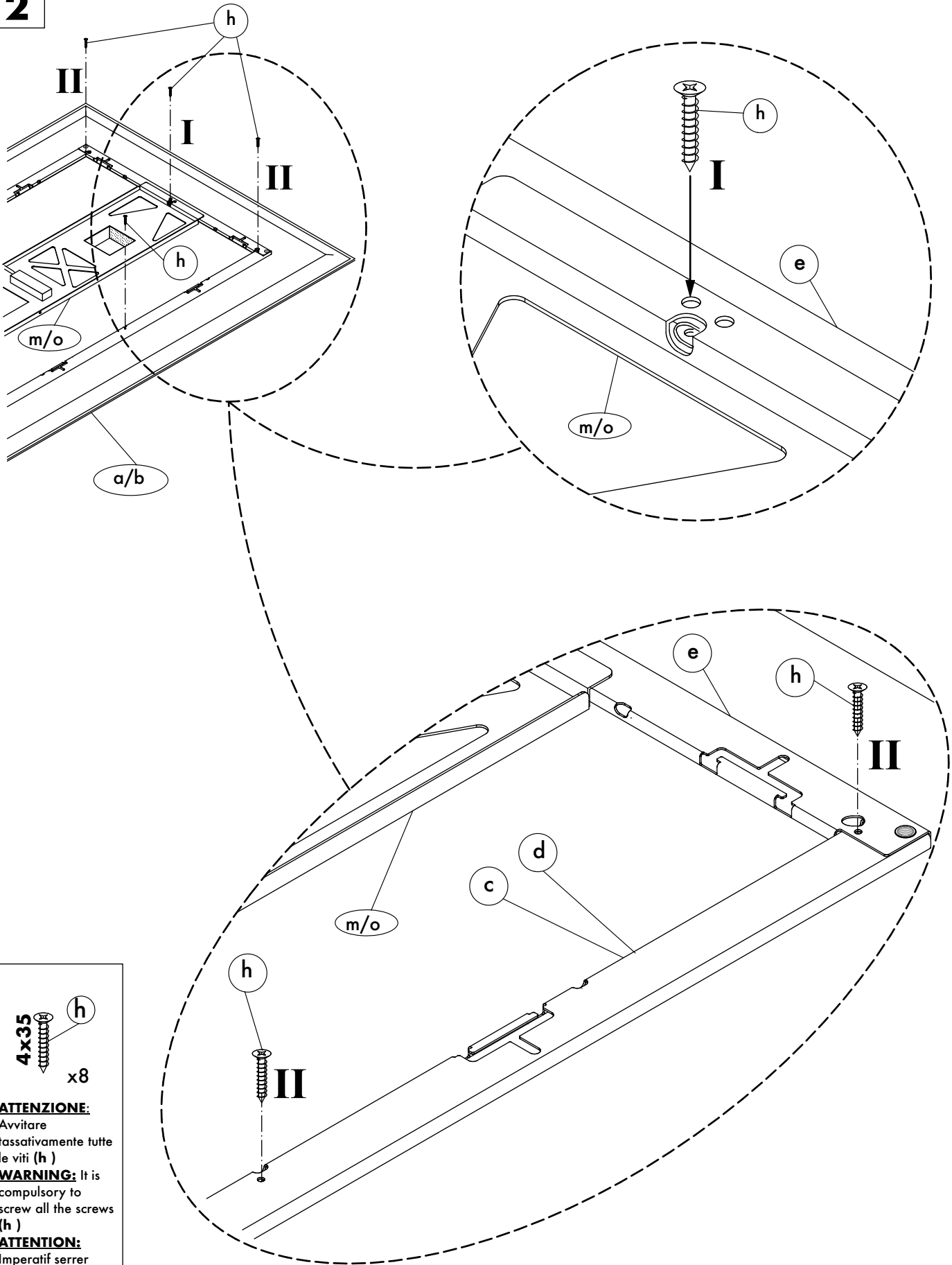
2

4x35
x8
h

ATTENZIONE:

Avvitare tassativamente tutte le viti (h)

WARNING: It is compulsory to screw all the screws (h)

ATTENTION:

Imperatif serrer toutes les vis (h)

ATENCIÓN:

Apretar obligatoriamente todos los tornillos (h)

ACHTUNG: Es müssen unbedingt alle Schrauben (h)

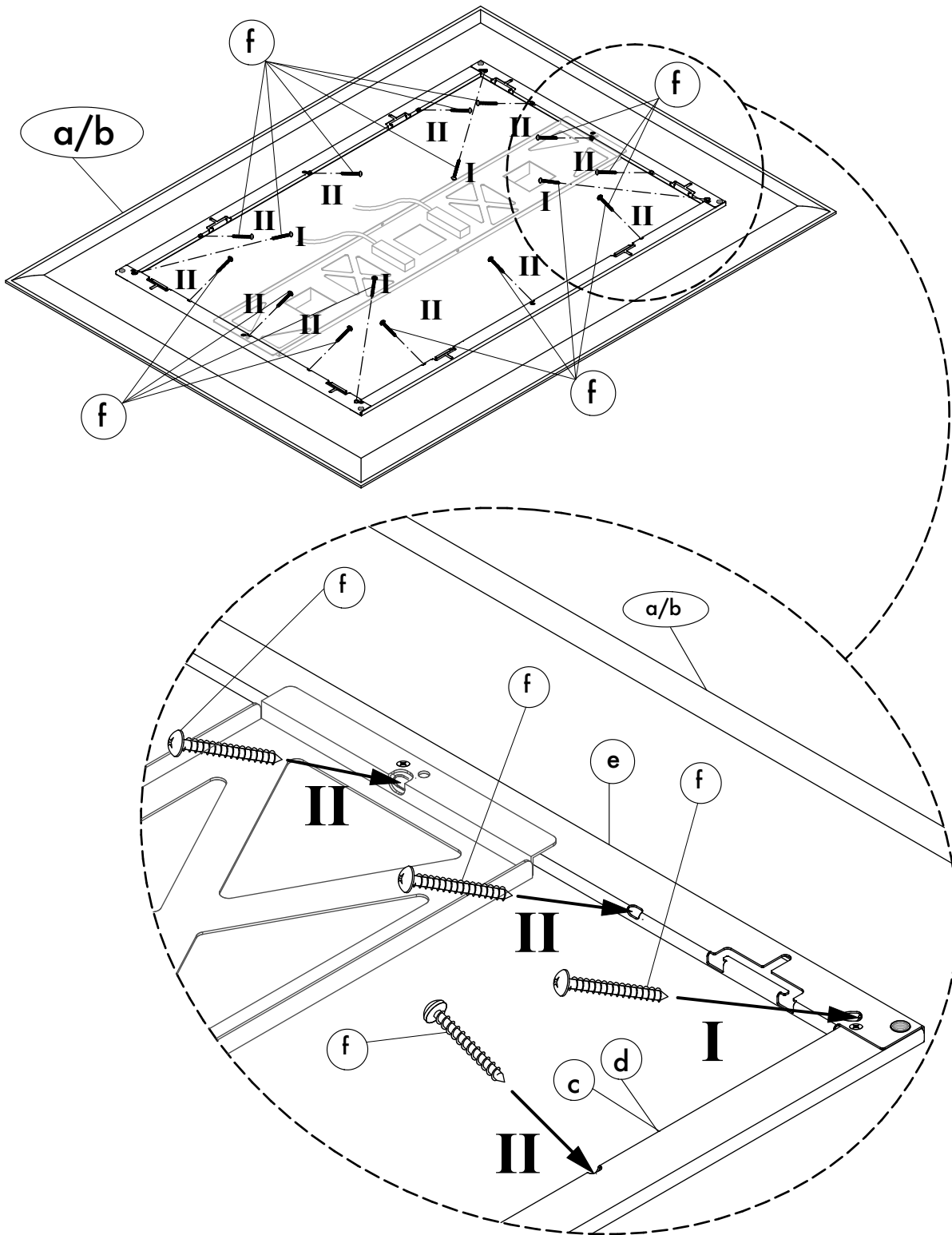

f

5x50

x16

ATTENZIONE: Avvitare tassativamente tutte le viti (f) di fissaggio tra il telaio (c/e-d/e) e i pannelli (a/b) **WARNING:** It is compulsory to screw the screws (f) fixing the frame (c/e-d/e) with the panels (a/b)

ATTENTION: Imperatif serrer toutes les vis (f) de fixation entre le châssis (c/e-d/e) et les panneaux (a/b) **ATENCIÓN:** Apretar obligatoriamente todos los tornillos (f) de fijación entre el bastidor (c/e-d/e) y los paneles (a/b)

ACHTUNG: Es müssen unbedingt alle Schrauben (f), die den Rahmen (c/e-d/e) mit den Paneelen (a/b) verbinden festgezogen werden

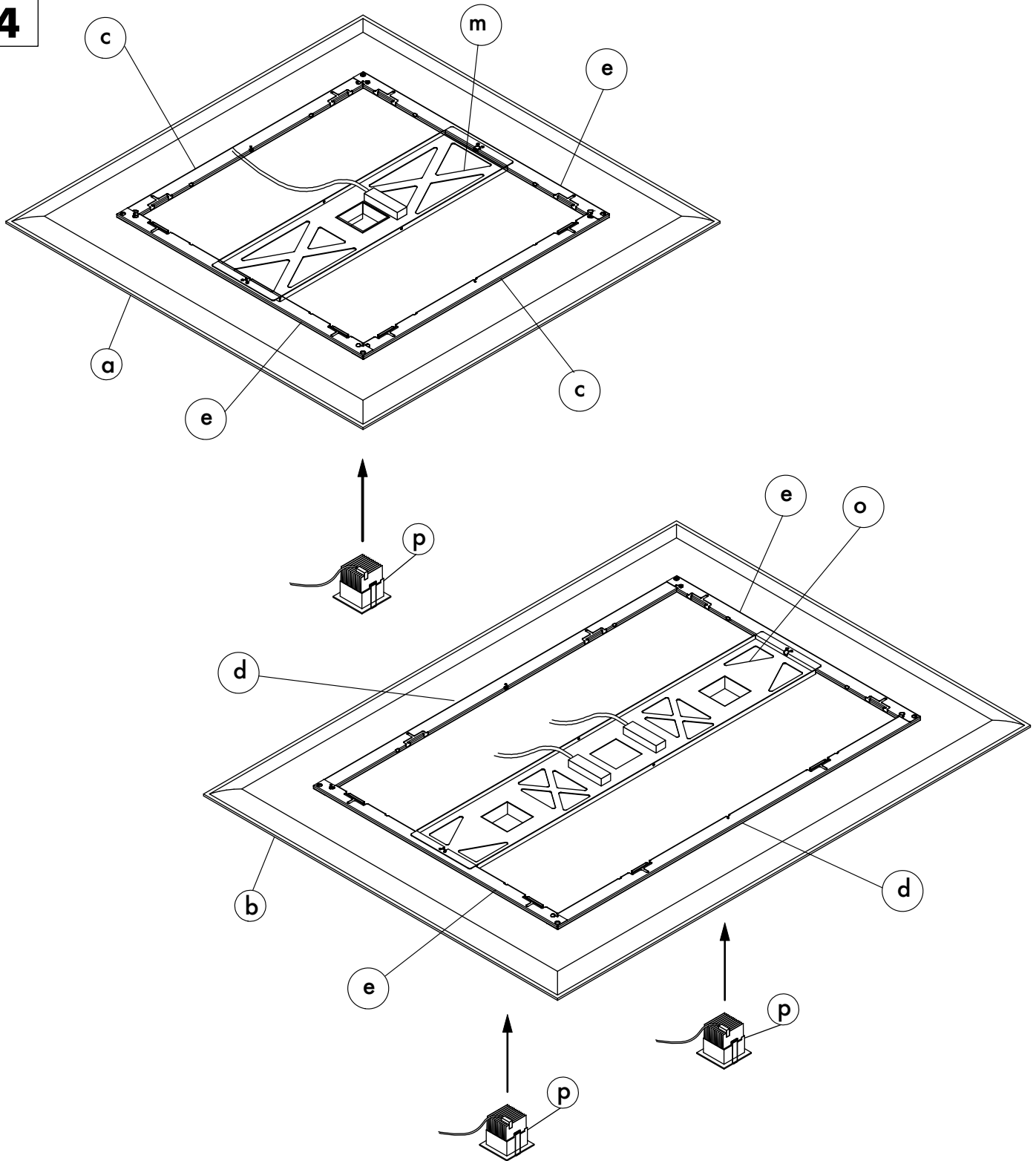
4

ATTENZIONE: la morsettiera non è inclusa nei **cod.751F120, 752F160 e 751F**. Il montaggio e l'installazione del prodotto deve essere effettuato esclusivamente da personale tecnico competente. Utilizzare per il cablaggio una morsettiera conforme alle norme EN60998-2-1 o EN60998-2-2

ATTENTION: terminalblock not included in **cod.751F120, 752F160 and 751F**. The product must only be assembled and installed by competent fitters. For the connection to the luminaire's wiring use a terminal conform to EN60998-2-1 o EN60998-2-2 standards.

ATTENTION: Le bornier n'est pas inclus dans les **cod.751F120, 752F160 et 751F**. Le montage et l'installation du produit doivent exclusivement être effectués par un personnel technique compétent. Utiliser pour le cablage un bornier conforme à la norme EN60998-2-1 ou EN 60998-2-2 standard.

ATENCIÓN: Bloque de terminales no incluido en los **cod.751F120, 752F160 y 751F**. El montaje y la instalación del producto debe efectuarlo exclusivamente personal técnico competente. Para la conexión del cableado de la luminaria se debe utilizar un bloque de terminales conforme a la normativa EN60998-2-1 o EN60998-2-2.

ACHTUNG: Der Klemmenblock ist nicht im Lieferumfang enthalten den **cod. cod.751F120, 752F160 und 751F**. Die Montage und die Aufstellung des Produktes dürfen ausschließlich von erfahrenem Fachpersonal ausgeführt werden. Für die Verkabelung einen Klemmenblock gemäss Norm EN60998-2-1 oder EN60998-2-2 verwenden.

ATTENZIONE: per l'installazione del **cod.751F120, 752F160 e 751F**, vedere attentamente le istruzioni allegate al corpo illuminante

ATTENTION: for the installation of **cod.751F120, 752F160 and 751F**, carefully read the instructions attached to the lighting element

ATTENTION: Pour l'installation de **cod.751F120, 752F160 et 751F**, lisez attentivement les instructions jointes aux l'élément d'éclairage

ATENCIÓN: Para la instalación del **cod.751F120, 752F160 y 751F**, lea cuidadosamente las instrucciones adjuntas all' elemento de iluminación

ACHTUNG: Für die Installation von **cod.751F120, 752F160 und 751F** lesen Sie bitte sorgfältig die Anweisungen im Scheinwerfer

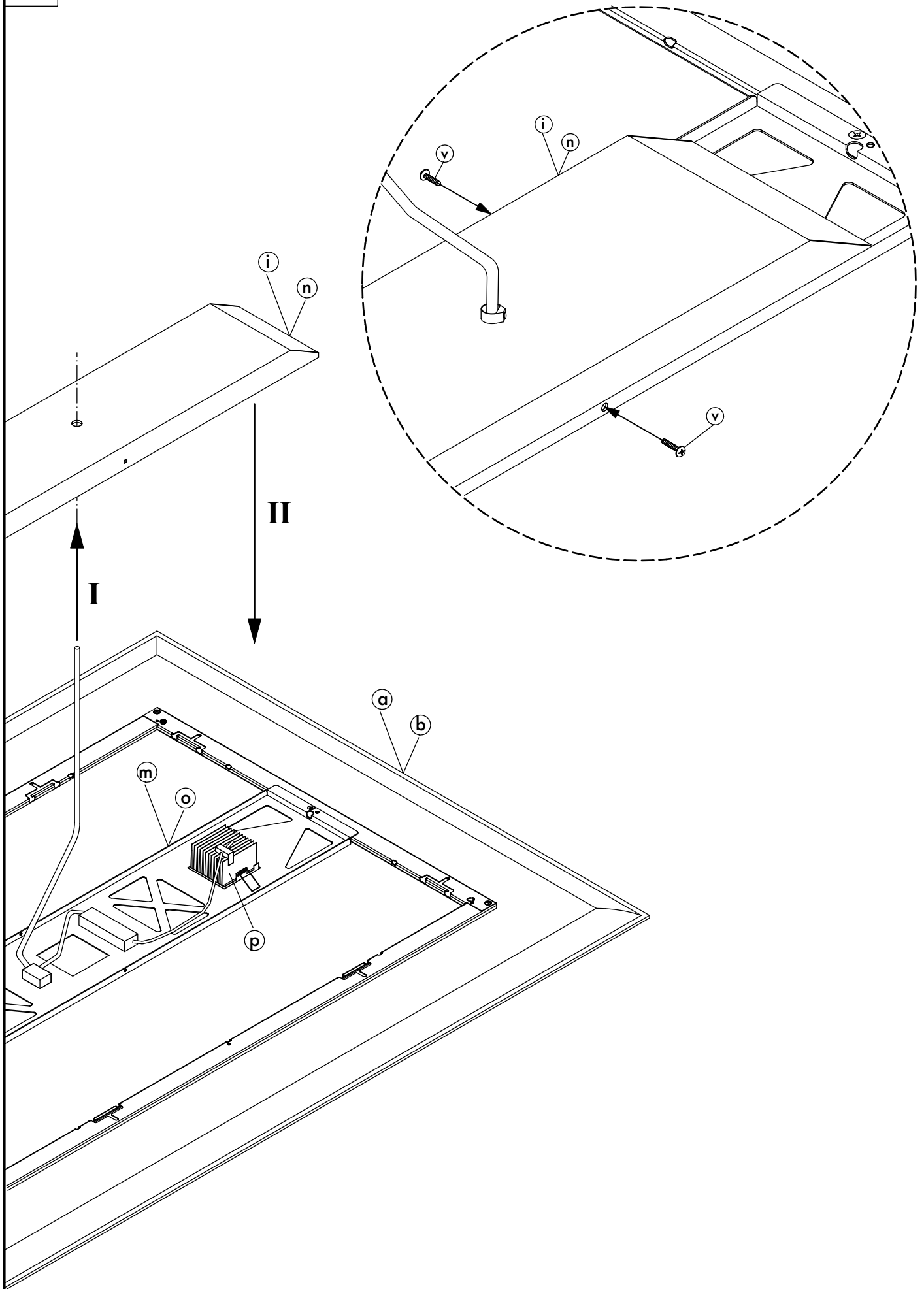

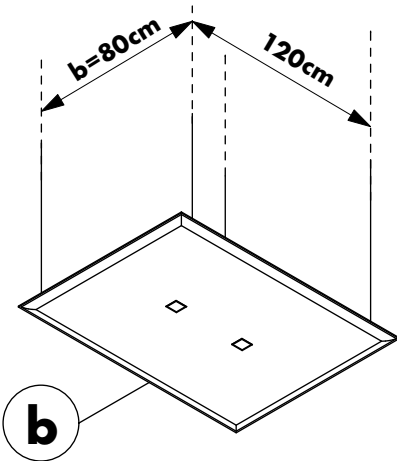
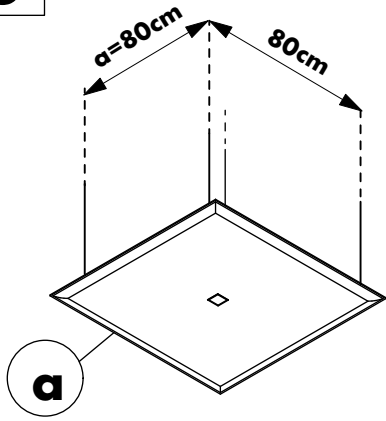
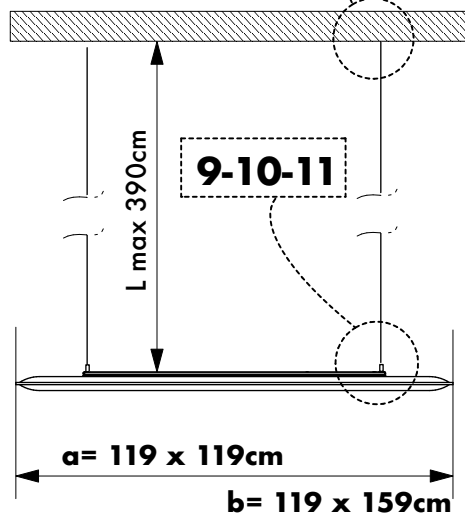
6**7/A - 7/B**codd.
75401+7SM6-C

OPTIONAL

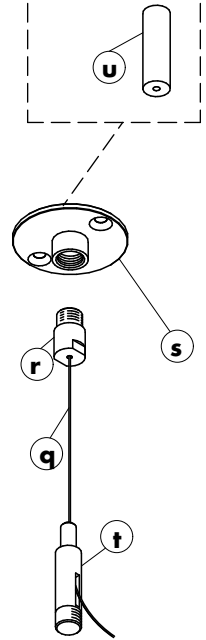
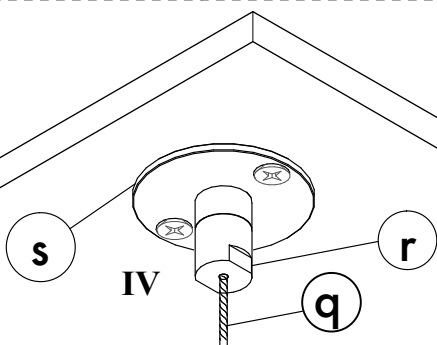
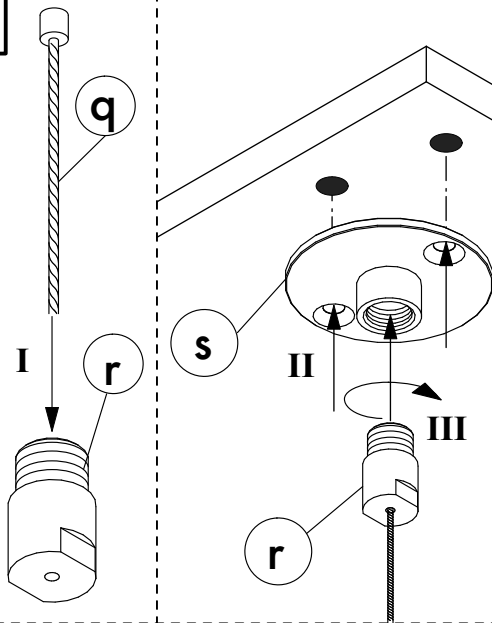
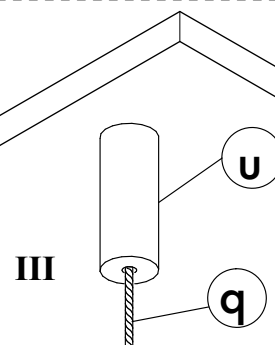
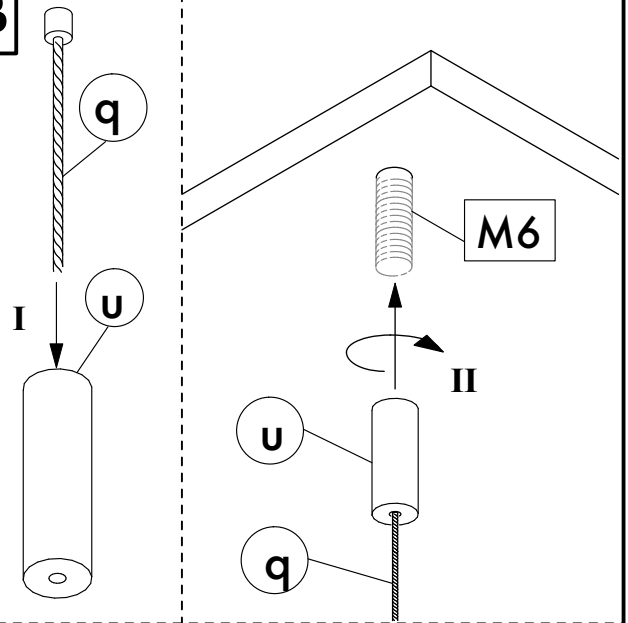
**7/A****7/B**

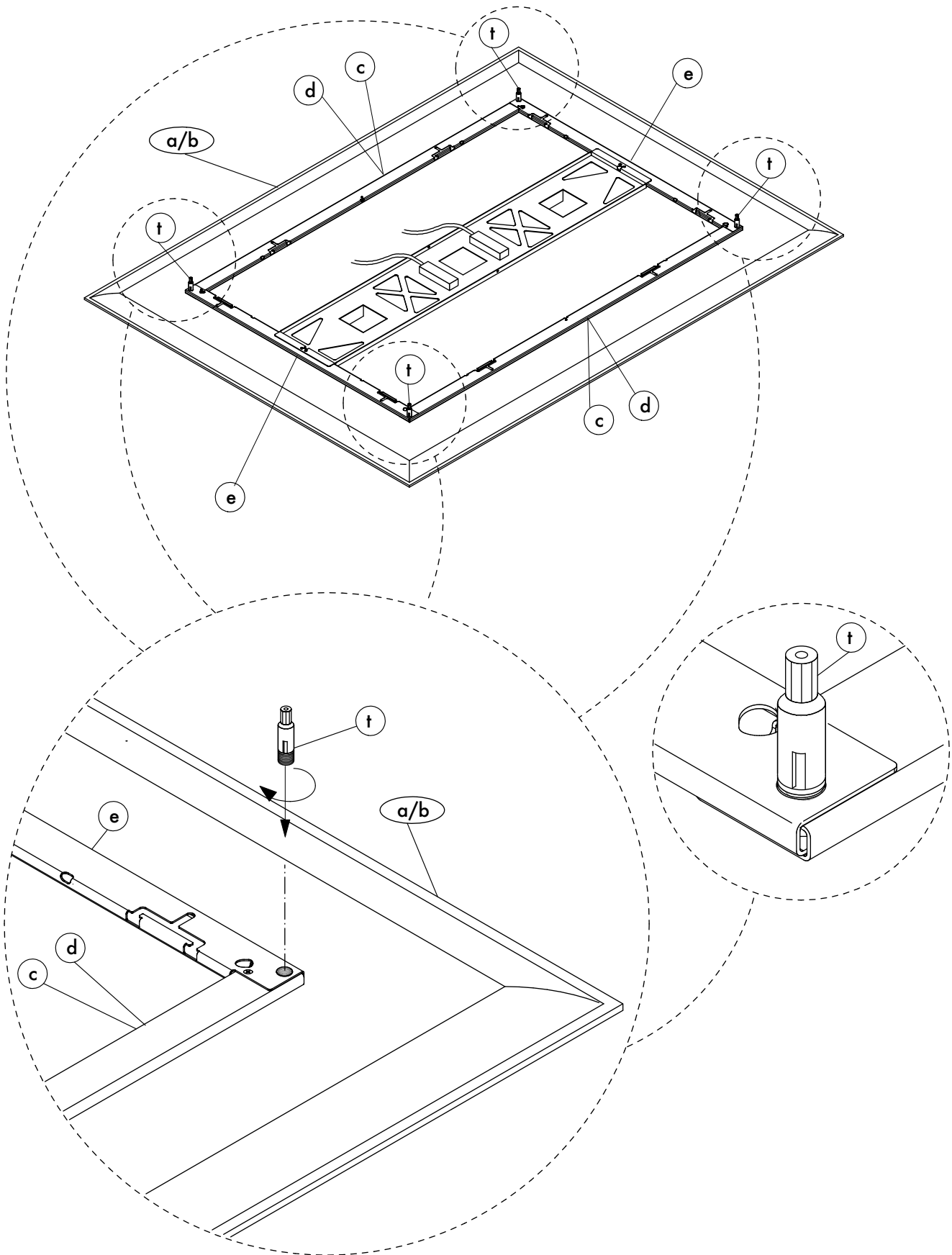

9

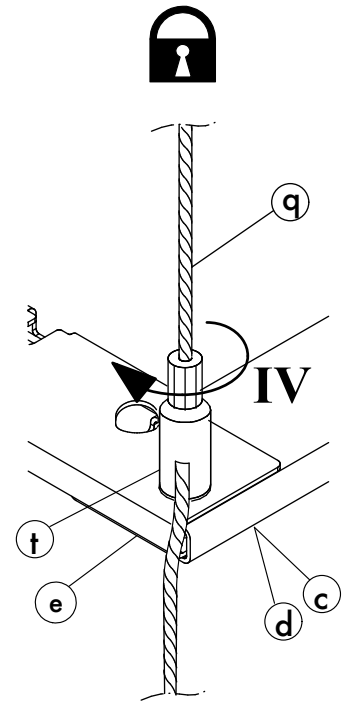
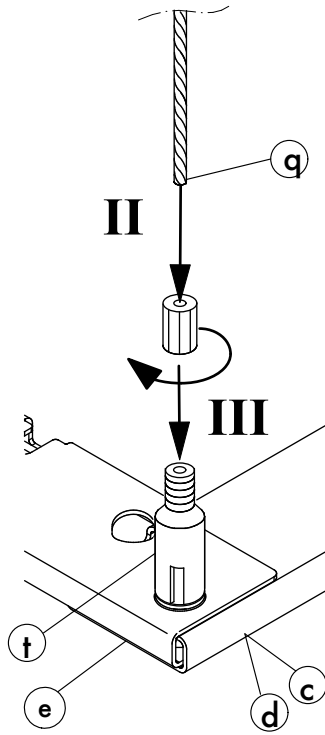
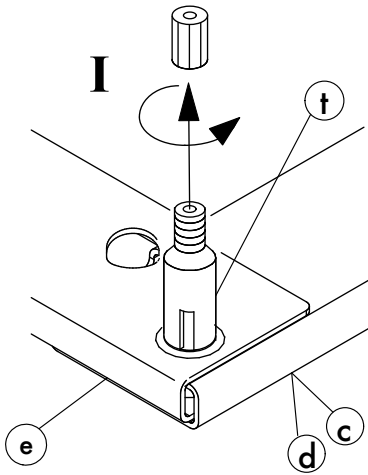

10

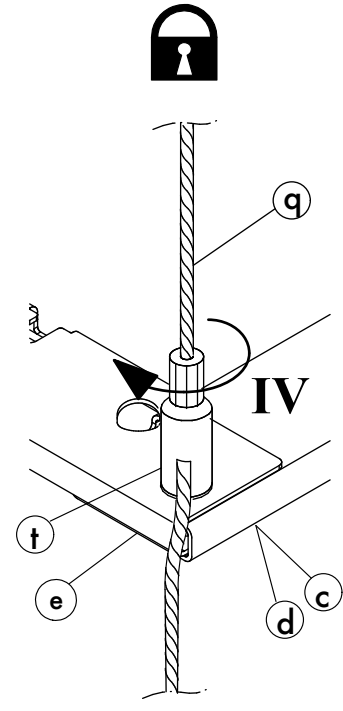
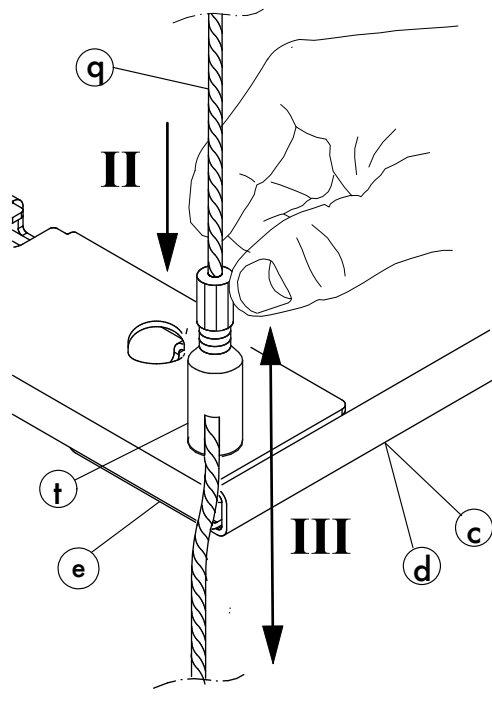
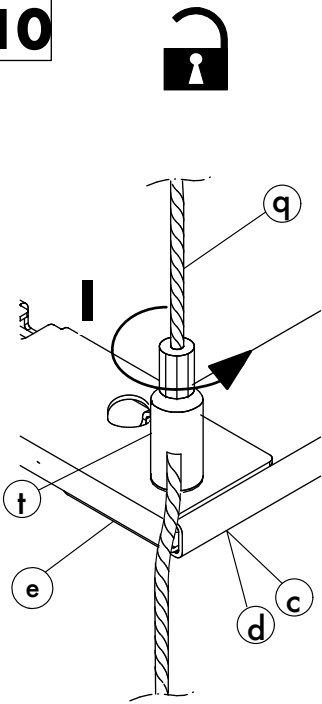

11

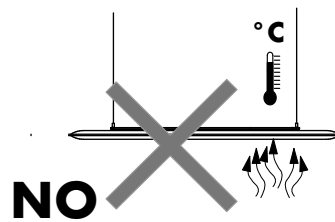
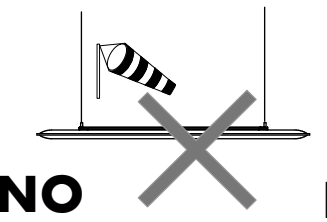
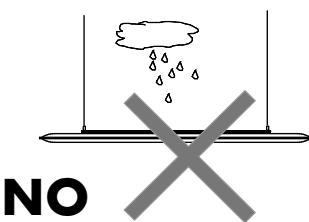
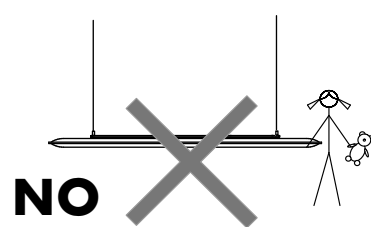
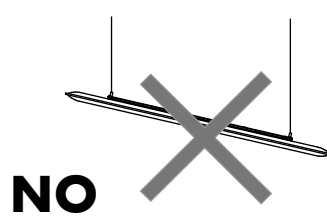
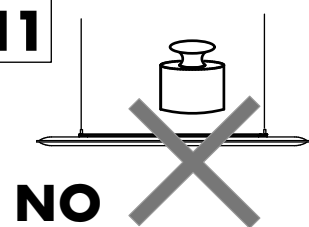

- tenere lontano da fonti di calore
- keep away from heat sources
- tenir loin de sources de chaleur
- mantener alejado de fuentes de calor
- Von Wärmequellen fernhalten

AVVERTENZE!

ISTRUZIONI E INFORMAZIONI PER LA SICUREZZA

prima di procedere al montaggio ed all'installazione del prodotto leggere attentamente le avvertenze di seguito riportate, prestando particolare attenzione ai disegni esplicativi riportati nelle istruzioni per il montaggio. Consultare queste avvertenze ad ogni successivo montaggio e/o installazione del prodotto.

1. Il montaggio e l'installazione del prodotto deve essere effettuato esclusivamente da personale tecnico competente. Attenzione: ultimato il montaggio verificare sempre che la struttura realizzata sia idonea al tipo di utenza e/o di utilizzo a cui è destinata. I prodotti non sono comunque idonei all'uso da parte di bambini.
2. Prima di procedere all'installazione è necessario verificare la portanza della superficie su cui verrà collocato il prodotto, di conseguenza utilizzare dispositivi di fissaggio adeguati al tipo di superficie in grado di resistere alle forze generate. Attenzione: la superficie deve comunque essere orizzontale, piana, rigida e indeformabile.
3. Attenzione: in caso di dubbi sulle modalità di installazione e/o sulla portanza della superficie su cui verrà collocato il prodotto non procedere alla installazione del prodotto.
4. ATTENZIONE: per l'installazione del cod.7S1F120, 7S2F160 e 7S1F, vedere attentamente le istruzioni allegate al corpo illuminante
5. Per la pulizia del pannello (a/b) utilizzare esclusivamente un prodotto smacchiatore a secco seguendo attentamente le istruzioni riportate sul prodotto utilizzato.
6. Per ulteriori informazioni sulle modalità di installazione del prodotto contattare il rivenditore. Per i casi non contemplati contattare il rivenditore.
7. Accertarsi periodicamente che i sistemi meccanici di serraggio siano opportunamente fissati.

NOTE!

SAFETY INSTRUCTIONS AND INFORMATION

Prior to assembling and installing the unit please read the following notes carefully. Pay particular attention to the drawings in the assembly instructions. Please consult these notes every time the product is assembled and/or installed.

1. The product must only be assembled and installed by competent fitters. Warning: once the product has been assembled always check that the structure is suitable for the type of application and/or use to which it will be put. These products are not suitable for use by children.
2. Prior to installation check the load bearing capacity of the surface on which the product is to be fitted, use suitable fixtures according to the type of surface which must be able to withstand the forces generated. Warning: the surface must be horizontal, flat, rigid and non-deformable
3. Warning: if you have any doubts concerning how to install the product and/or the load bearing capacity of the surface on which it will be fitted, do not fit it.
4. ATTENTION: for the installation of cod.7S1F120, 7S2F160 and 7S1F, carefully read the instructions attached to the lighting element
5. To clean the panel (a/b) use only a dry stain removal, carefully following the instructions on the product used.
6. For further information on how to install the product, please contact your dealer. For any use different from the ones here shown please contact the dealer.
7. Periodically check that the mechanical tightening systems are properly fixed.

MISES EN GARDE!

INSTRUCTIONS ET INFORMATIONS DE SÉCURITÉ

Avant de procéder au montage et à l'installation du produit, lire attentivement les mises en garde ci-dessous présentées, en faisant particulièrement attention aux dessins explicatifs rapportés dans les instructions de montage. Consulter ces mises en garde lors de chaque montage successif et/ou installation du produit.

1. Le montage et l'installation du produit doivent exclusivement être effectués par un personnel technique compétent. Attention: au terme du montage, toujours vérifier si la structure réalisée est appropriée au type d'usagers et/ou d'utilisation auxquels elle est destinée. Les produits ne sont pas destinés aux enfants.
2. Avant de procéder à l'installation, il est nécessaire de vérifier la capacité de charge de la surface sur laquelle le produit sera installé: en conséquence, utiliser les dispositifs de fixation adaptés au type de surface et qui peuvent résister aux forces produites. Attention: la surface doit être horizontale, plane, rigide et indeformable.
3. Attention: en cas de doute sur les modalités d'installation et/ou sur la capacité de charge de la surface sur laquelle le produit sera installé, ne pas monter le produit.
4. ATTENTION: Pour l'installation de cod.7S1F120, 7S2F160 et 7S1F, lisez attentivement les instructions jointes aux l'élément d'éclairage
5. Pour le nettoyage du panneau (a/b) utiliser seulement un détachant à sec en suivant soigneusement les instructions sur le produit utilisé.
6. Pour toute information complémentaire sur les modalités d'installation, contacter le revendeur. Pour emploi différent par rapport à ceux indiqués ici nous vous prions de contacter le revendeur.
7. Vérifier périodiquement que les systèmes mécaniques de serrage soient opportunément fixés.

¡ADVERTENCIAS!

INSTRUCCIONES E INFORMACIÓN DE SEGURIDAD

Antes de realizar el montaje y la instalación del producto leer atentamente las advertencias que se indican a continuación, prestando especial atención a los dibujos y a las instrucciones para el montaje. Consultar estas advertencias cada vez que se monte y/o instale el producto.

1. El montaje y la instalación del producto debe efectuarlo exclusivamente personal técnico competente. Atención: una vez acabado el montaje, hay que comprobar siempre que la estructura realizada sea apta para el tipo de servicio y/o uso al que se va a destinar. Los productos no son aptos para niños.
2. Antes de realizar la instalación es necesario controlar la capacidad de carga de la superficie en la que se colocará el producto: por consiguiente, hay que utilizar dispositivos de fijación adecuados para el tipo de superficie capaces de resistir las fuerzas generadas. Atención: la superficie debe en cualquier caso ser horizontal, plana, rígida e indeformable.
3. Atención: en caso de duda sobre las modalidades de instalación y/o sobre la capacidad de carga de la superficie en la que se vaya a colocar el producto, éste no deberá instalarse.
4. ATENCIÓN: Para la instalación del cod.7S1F120, 7S2F160 y 7S1F, lea cuidadosamente las instrucciones adjuntas al elemento de iluminación
5. Para la limpieza del panel (a/b) utilizar exclusivamente un producto quitamanchas seco, siguiendo atentamente las instrucciones que aparecen sobre el producto utilizado
6. Para más información sobre las modalidades de instalación del producto, ponerse en contacto con el vendedor. Para cualquier otra utilización por favor consulte con su distribuidor.
7. Verificar periódicamente que los sistemas mecánicos de cierres sean correctamente fijados.

WICHTIG!

SICHERHEITSHINWEISE UND INFORMATIONEN

Vor der Montage und der Aufstellung des Produktes folgende Anleitungen sorgfältig lesen und dabei die Einbauzeichnungen, die in den Montageanleitungen zu finden sind genau beachten. Die wichtigen Anweisungen bezüglich der Montage und/oder Aufstellung des Produktes sind nachzusehen.

1. Die Montage und die Aufstellung des Produktes dürfen ausschließlich von erfahrenem Fachpersonal ausgeführt werden. Vorsicht: sich nach der Montage immer vergewissern, dass die aufgestellte Struktur ihren Verwendungszwecken und/oder dem Benutzerkreis entspricht. Es ist aber dabei nicht zu vergessen, daß der Gebrauch dieser Produkte Kindern untersagt ist.
2. Vor jeglicher Montage die Oberfläche, an der das Produkt montiert werden soll, auf ihre Tragfähigkeit prüfen und passende Befestigungsmittel welche die erzeugten Kräfte aushalten können je nach Art der Oberfläche benutzen. Vorsicht: die Bodenfläche immer waagrecht, flach, steif und unverformbar sein.
3. Wichtig: bestehen Zweifel über die Einbaumodalitäten und /oder über die Tragfähigkeit der betroffenen Oberfläche, Produkt nicht aufstellen.
4. ACHTUNG: Für die Installation von cod.7S1F120, 7S2F160 und 7S1F lesen Sie bitte sorgfältig die Anweisungen im Scheinwerfer
5. Zur Reinigung der Akustikpaneele (a/b) darf nur Schaumreiniger verwendet werden, wobei die Anleitung auf dem gewählten Produkt genau zu befolgen ist.
6. Für weitere Angaben über die Aufstellungsmodalitäten wenden Sie sich bitte an Ihren Wiederverkäufer. Für alle Anlagen, die nicht aufgeführt sind, kontaktieren Sie bitte vor dem Einbau den Fachhandelspartner.
7. Kontrollieren Sie periodisch die mechanische Befestigung.

MOD. 499 / L2



Caimi
BREVETTI

OVERSIZE LUX

Design: Caimi Lab

* (xx = variante colore, colour alternative, variante couleur, variante color, Farbe Variante)

codd.7OL1212/L6-xx*
7OL1212/D6-xx*

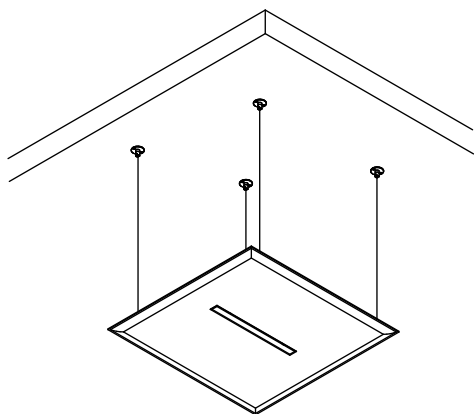

codd.7OL1216/L9-xx*
7OL1216/D9-xx*

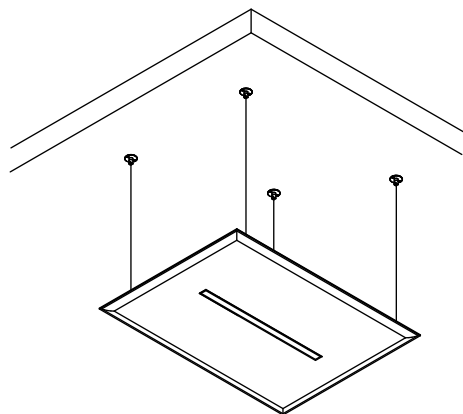



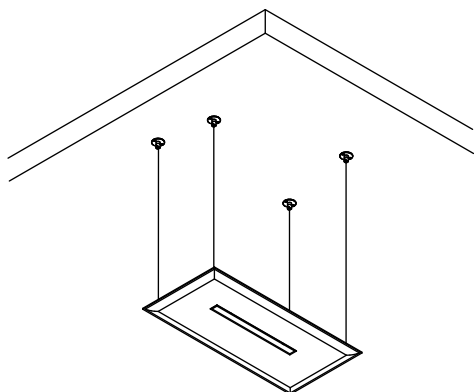



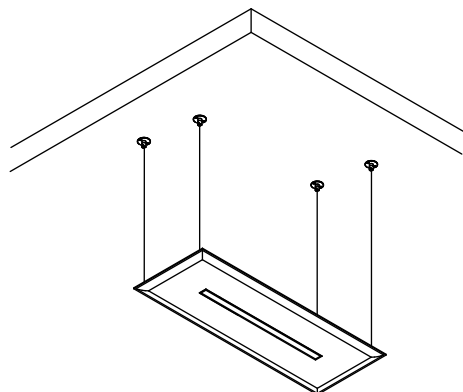

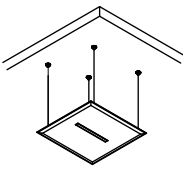
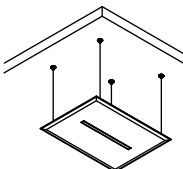
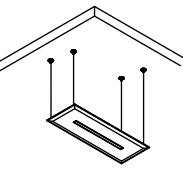
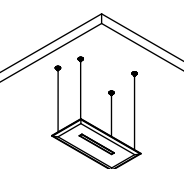
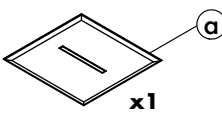
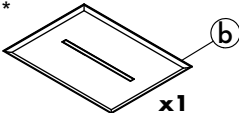
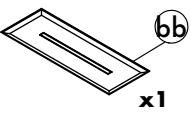
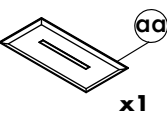
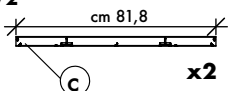

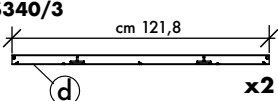



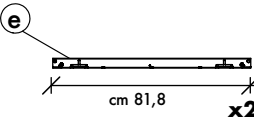

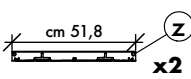
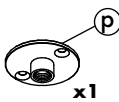

codd.7OL1206/L6-xx*
7OL1206/D6-xx*

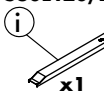
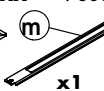
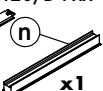

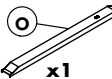
codd.7OL1606/L9-xx*
7OL1606/D9-xx*

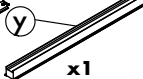

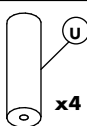
	70L1212/L6-xx* 70L1212/D6-xx*	70L1216/L9-xx* 70L1216/D9-xx*	70L1606/L9-xx* 70L1606/D9-xx*	70L1206/L6-xx* 70L1206/D6-xx*
				
751212/L6-xx*  x1	x1			
751216/L9-xx*  x1		x1		
75166/L6-xx*  x1				x1
75126/L9-xx*  x1			x1	
75340/2  x2  f x16  h x8	x1			x1
75340/3  x2  f x16  h x8		x1	x1	
75340/1  g x4 M10x1  e x2 cm 81,8	x1	x1		
75340/4  g x4 M10x1  z x2 cm 51,8			x1	x1
75401  p x1  q x1  r x1	x4	x4	x4	x4
75RM10-C  f x1	x4	x4	x4	x4
7560L120-xx* 7560L120/D-xx*  i x1  m x1  n x1 M4x20  v x2 M4x20  w x2	x1		x1	
7590L160-xx* 7590L160/D-xx*  o x1  s x1  y x1 M4x20  v x2 M4x20  w x2		x1		x1
75M6-xx*  u x4	OPTIONAL	OPTIONAL	OPTIONAL	OPTIONAL

7SL/RD7
OPTIONAL

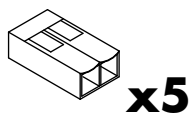
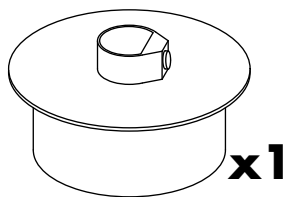

ATTENZIONE: per l'installazione vedere attentamente le istruzioni allegate al corpo illuminante
ATTENTION: for the installation carefully read the instructions attached to the lighting element
ATTENTION: Pour l'installation lisez attentivement les instructions jointes aux l'élément d'éclairage
ATENCIÓN: Para la instalación lea cuidadosamente las instrucciones adjuntas all' elemento de iluminación
ACHTUNG: Für die Installation lesen Sie bitte sorgfältig die Anweisungen im Scheinwerfer

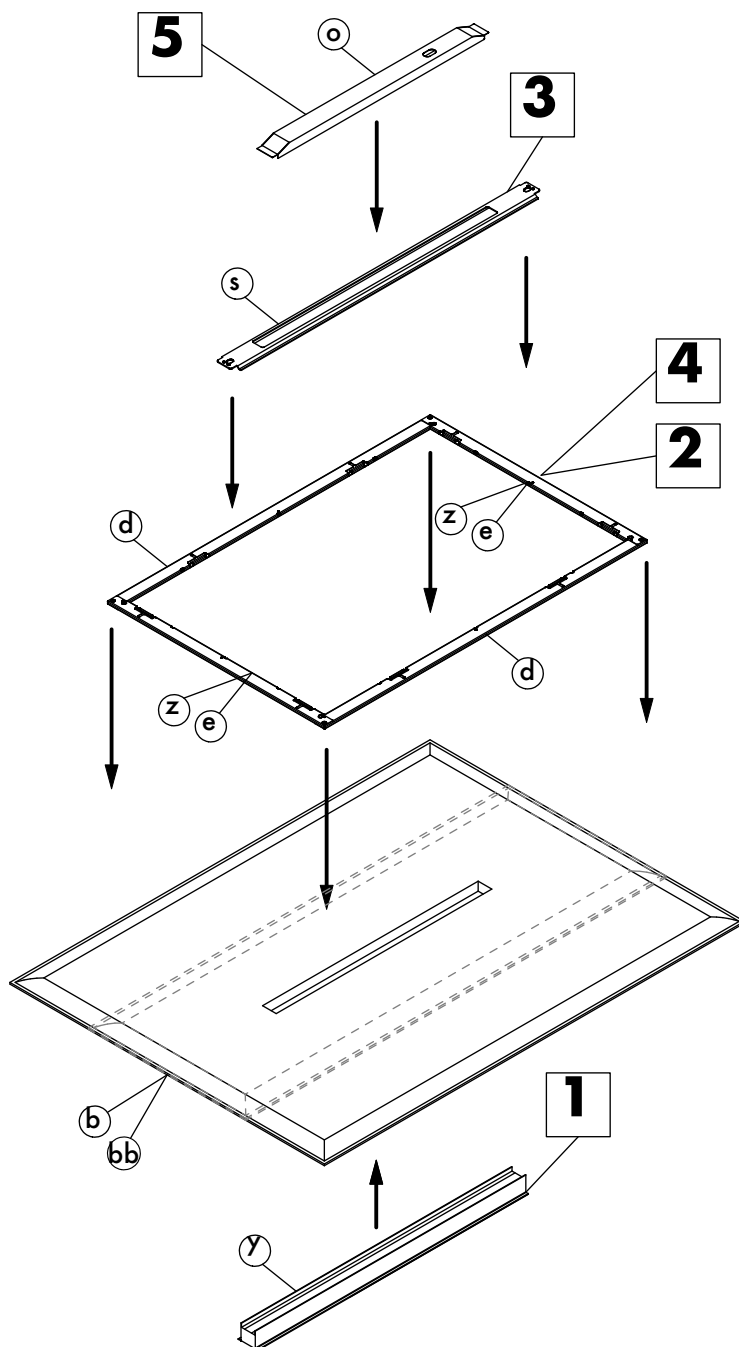
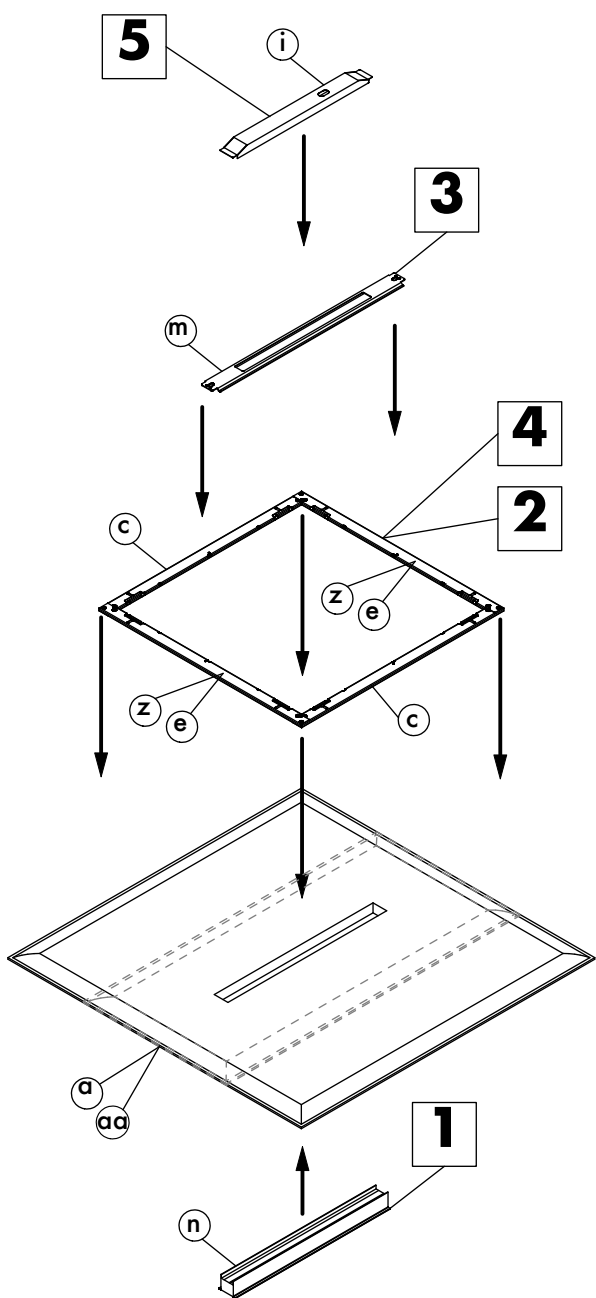

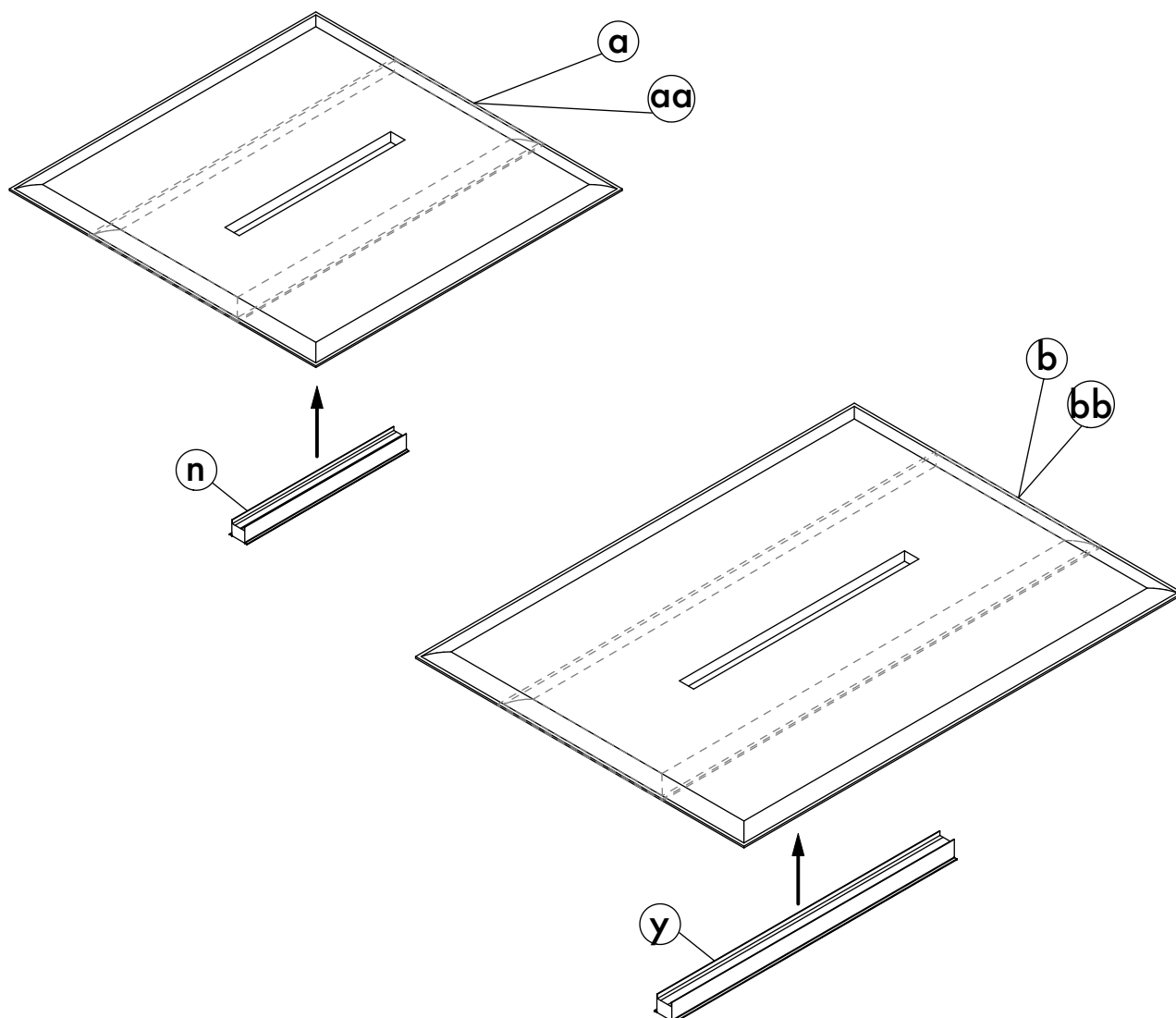
1**ATTENZIONE:**

1 - per l'installazione del codd.7S60L120, 7S60L120/D (7S60L120/4, 7S60L120/D4) e codd.7S90L160, 7S90L160/D (7S90L160/4, 7S90L160/D4) vedere attentamente le istruzioni allegate al corpo illuminante

2 - la morsettiere non è inclusa. L'installazione può richiedere personale qualificato. Utilizzare per il cablaggio una morsettiere con morsetti a vite di sez.2,5mm, conforme alle norme EN60996-2-1 o EN60996-2-2

ATTENTION:

1 - for the installation of codd.7S60L120, 7S60L120/D (7S60L120/4, 7S60L120/D4) and codd.7S90L160, 7S90L160/D (7S90L160/4, 7S90L160/D4), carefully read the instructions attached to the lighting element

2 - terminal block not included. Installation may require advice from a qualified person. For the connection to the luminaire's wiring use with screws size 2,5mm, conform to EN60996-2-1 o EN60996-2-2 standards

ATTENTION:

1 - Pour l'installation de codd.7S60L120, 7S60L120/D (7S60L120/4, 7S60L120/D4) et codd.7S90L160, 7S90L160/D (7S90L160/4, 7S90L160/D4), lisez attentivement les instructions jointes aux l'élément d'éclairage

2 - Le bornier n'est pas inclus. L'installation peut nécessiter d'une personne qualifiée. Utiliser pour le câblage, un bornier avec des bornes à vis de 2,5mm² conforme à la norme EN60998-2-1 ou EN 60998-2-2 standard.

ATENCIÓN:

1 - Para la instalación del codd.7S60L120, 7S60L120/D (7S60L120/4, 7S60L120/D4) y codd.7S90L160, 7S90L160/D (7S90L160/4, 7S90L160/D4), lea cuidadosamente las instrucciones adjuntas al elemento de iluminación

2 - Bloque de terminales no incluido. La instalación debe realizarse por una persona cualificada. Para la conexión del cableado de la luminaria se debe utilizar un bloque de terminales con tornillos de 2,5 mm² conforme a la normativa EN60998-2-1 o EN60998-2-2.

ACHTUNG:

1 - Für die Installation von codd.7S60L120, 7S60L120/D (7S60L120/4, 7S60L120/D4) und codd.7S90L160, 7S90L160/D (7S90L160/4, 7S90L160/D4) lesen Sie bitte sorgfältig die Anweisungen im Scheinwerfer

2 - Der Klemmenblock ist nicht enthalten. Die Installation hat durch eine Fachkraft zu erfolgen. Für die Verkabelung einen Klemmenblock mit Schrauben, für Kabelquerschnitt 2,5mm², gemäß Norm EN60998-2-1 oder EN60998-2-2 verwenden.

2

- Posizionare il telaio sul pannello senza fissarlo

- Position frame on Panel without fixing it

- Positionnez le cadre sur panneau sans fixation

- Coloque el marco en el Panel sin fijarlo

- Standpunkt-Frame auf Panel ohne Fixierung

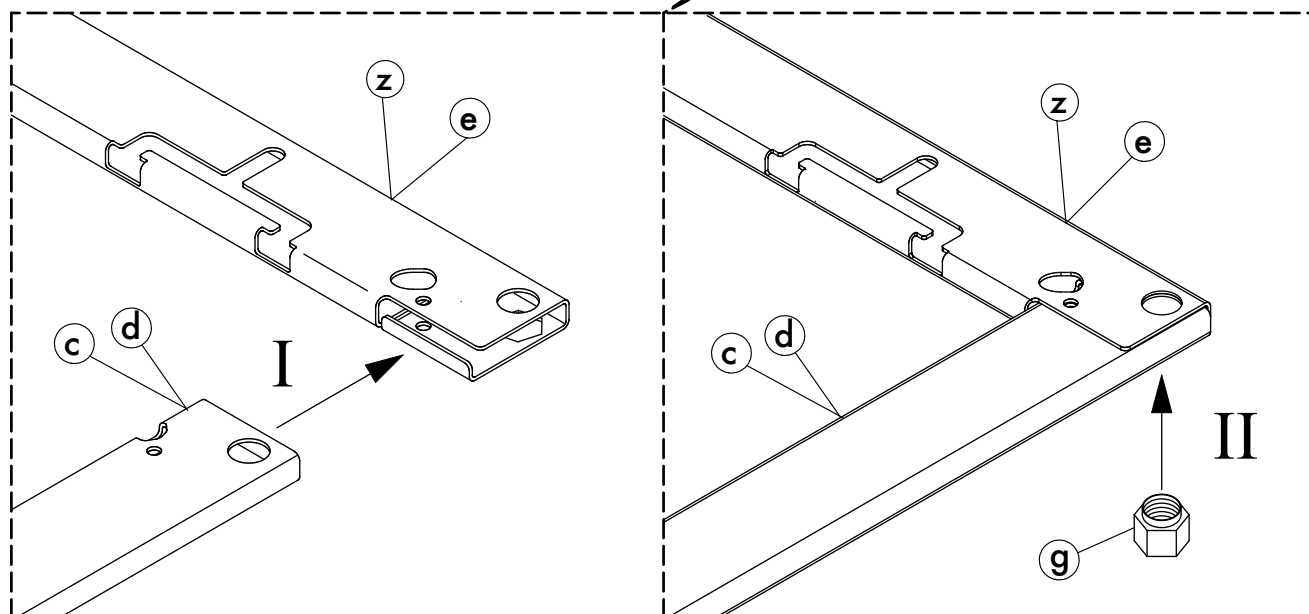
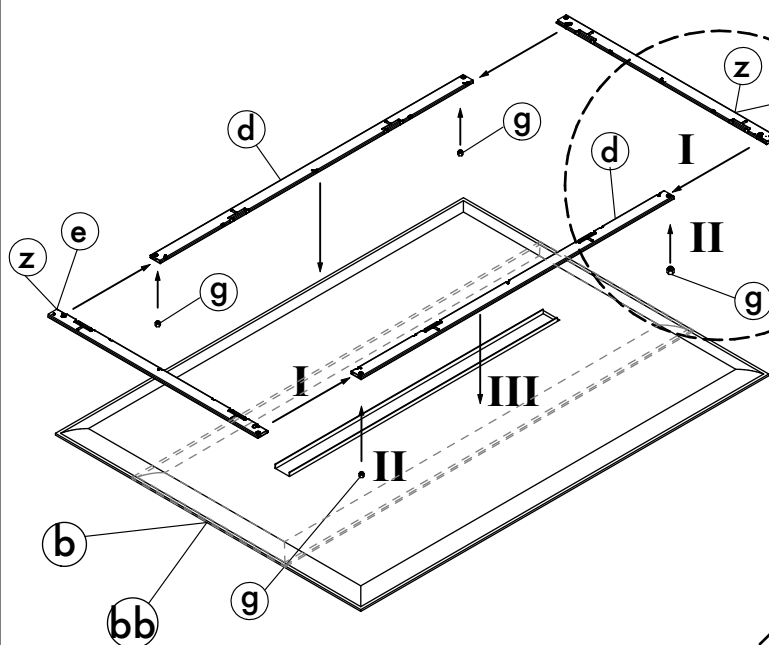
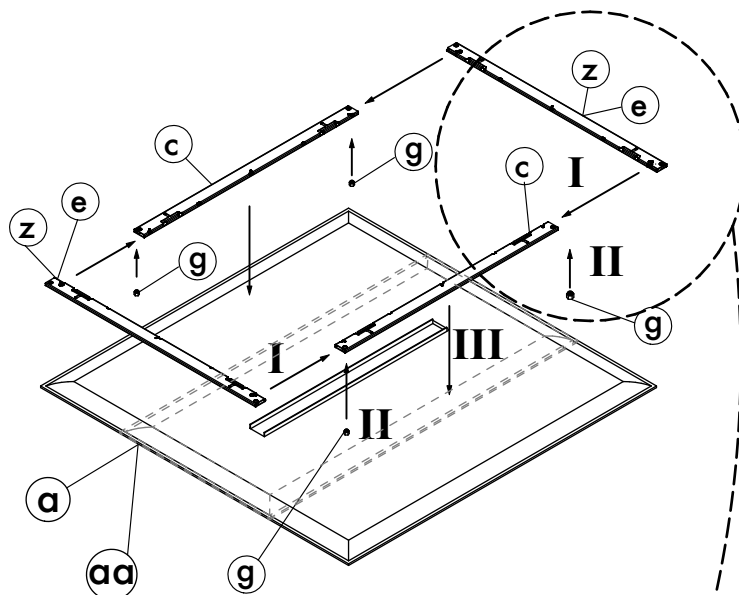

3

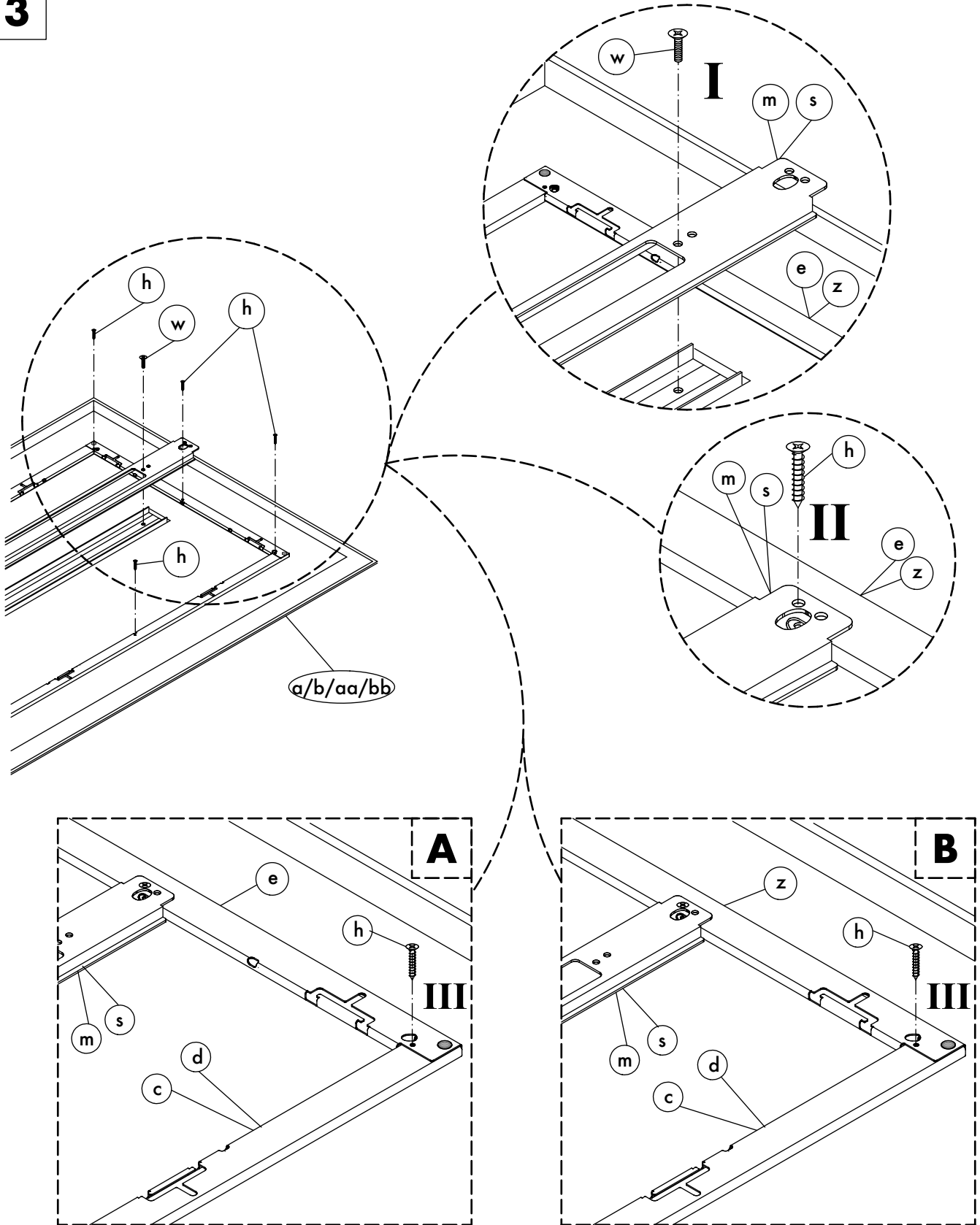

a/b/aa/bb

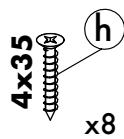

ATTENZIONE: Avvitare tassativamente tutte le viti (**h**)
WARNING: It is compulsory to screw all the screws (**h**)
ATTENTION: Imperatif serrer toutes les vis (**h**)
ATENCIÓN: Apretar obligatoriamente todos los tornillos (**h**)
ACHTUNG: Es müssen unbedingt alle Schrauben (**h**)

4 - A

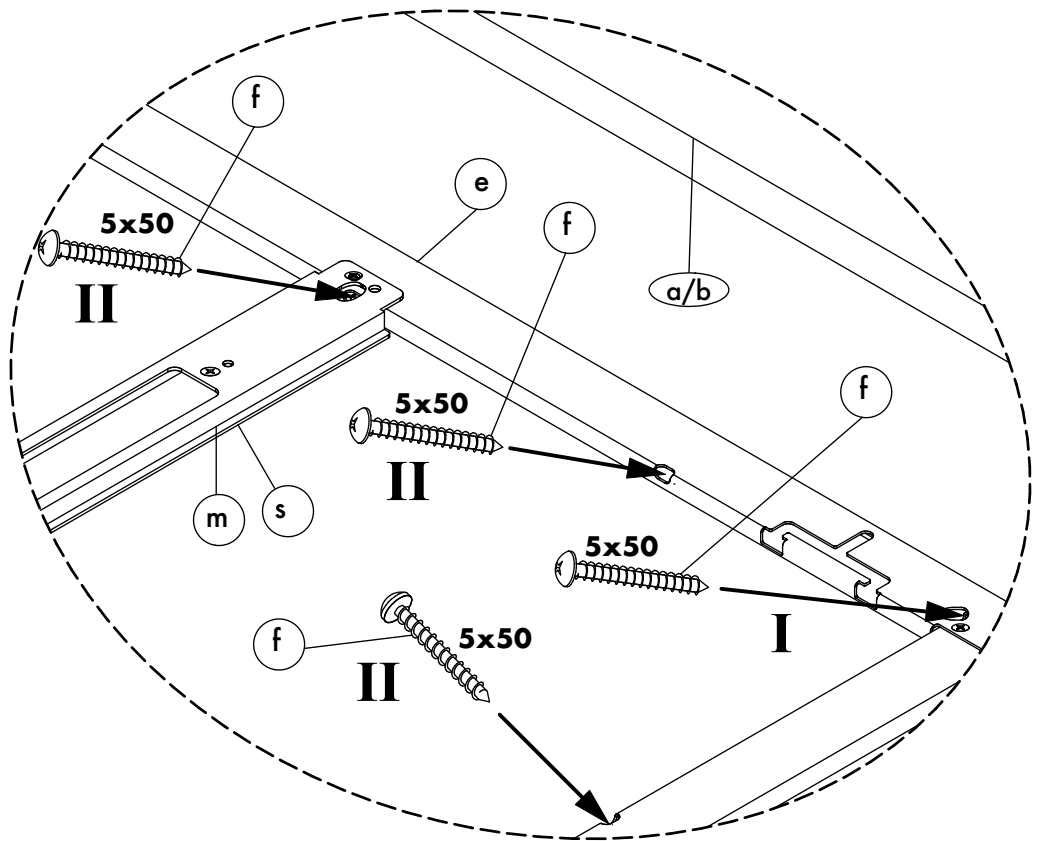
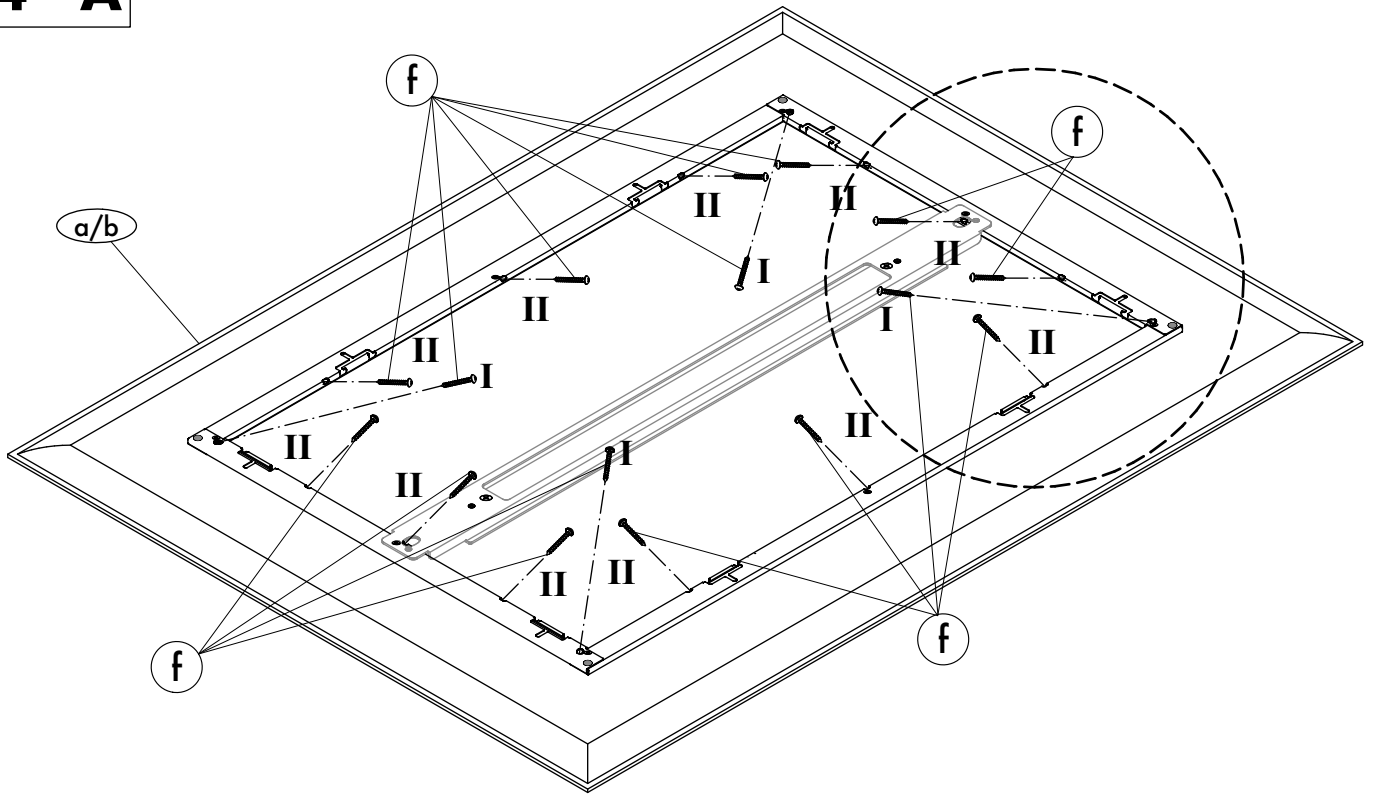

a/b

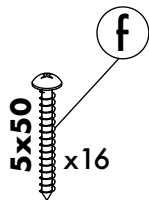

ATTENZIONE: Avvitare tassativamente tutte le viti (**f**) di fissaggio tra il telaio e i pannelli (**a/b**)
WARNING: It is compulsory to screw the screws (**f**) fixing the frame with the panels (**a/b**)
ATTENTION: Imperatif serrer toutes les vis (**f**) de fixation entre le châssis et les panneaux (**a/b**)
ATENCIÓN: Apretar obligatoriamente todos los tornillos (**f**) de fijación entre el bastidor y los paneles (**a/b**)
ACHTUNG: Es müssen unbedingt alle Schrauben (**f**), die den Rahmen mit den Paneelen (**a/b**) verbinden festgezogen werden

4 - B

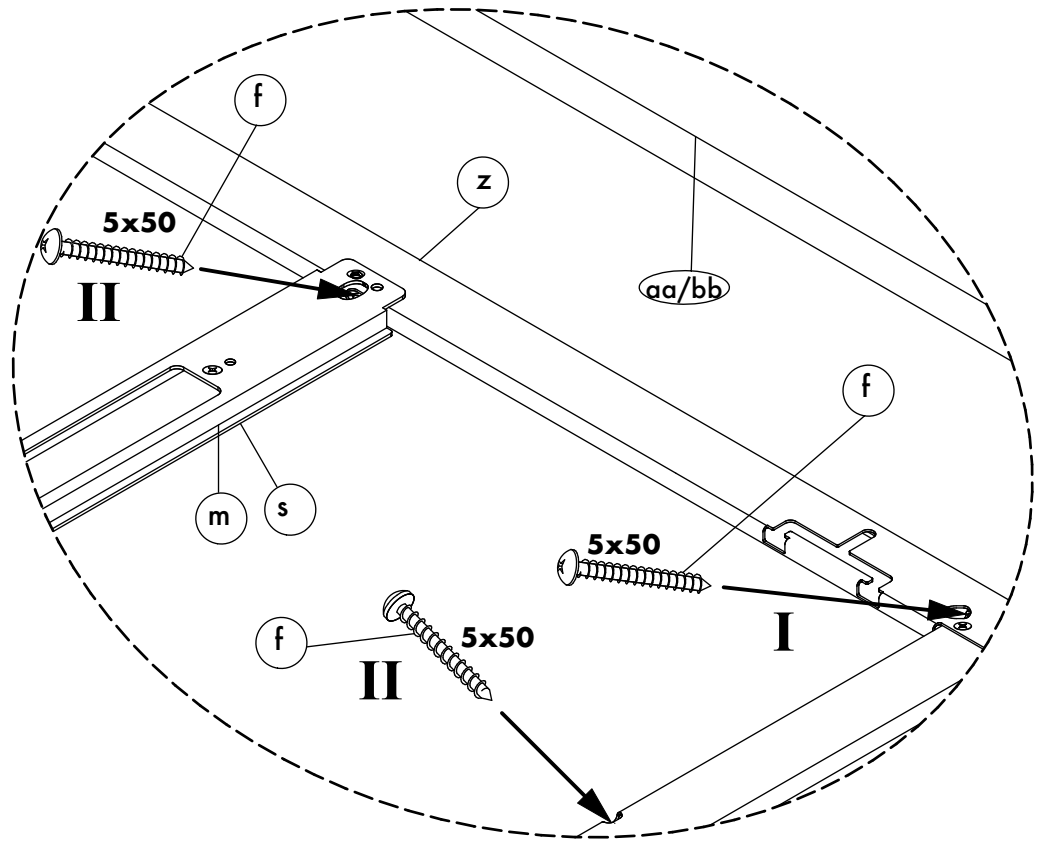
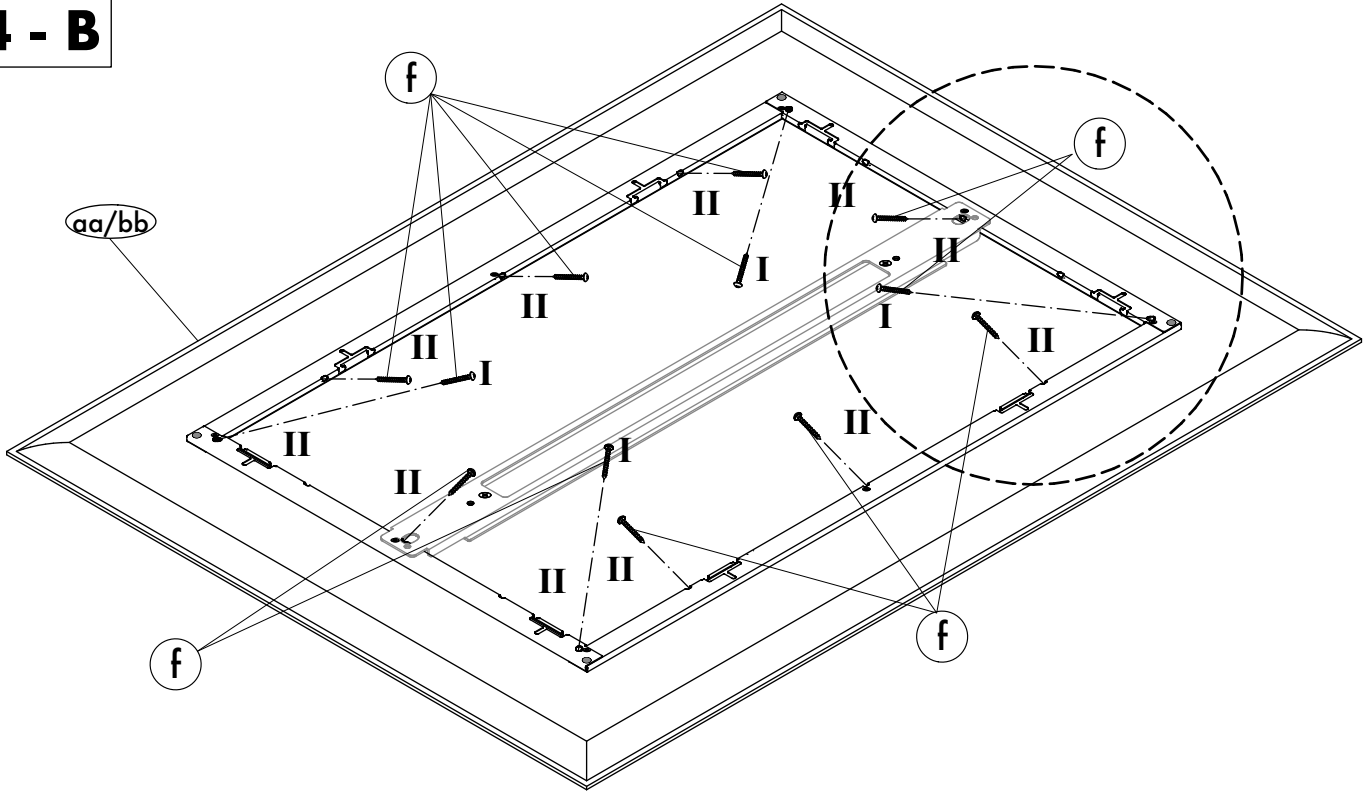

aa/bb

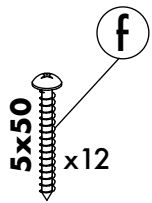

ATTENZIONE: Avvitare tassativamente tutte le viti (f) di fissaggio tra il telaio e i pannelli (aa/bb)
WARNING: It is compulsory to screw the screws (f) fixing the frame with the panels (aa/bb)
ATTENTION: Imperatif serrer toutes les vis (f) de fixation entre le châssis et les panneaux (aa/bb)
ATENCIÓN: Apretar obligatoriamente todos los tornillos (f) de fijación entre el bastidor y los paneles (aa/bb)
ACHTUNG: Es müssen unbedingt alle Schrauben (f), die den Rahmen mit den Paneelen (aa/bb) verbinden festgezogen werden

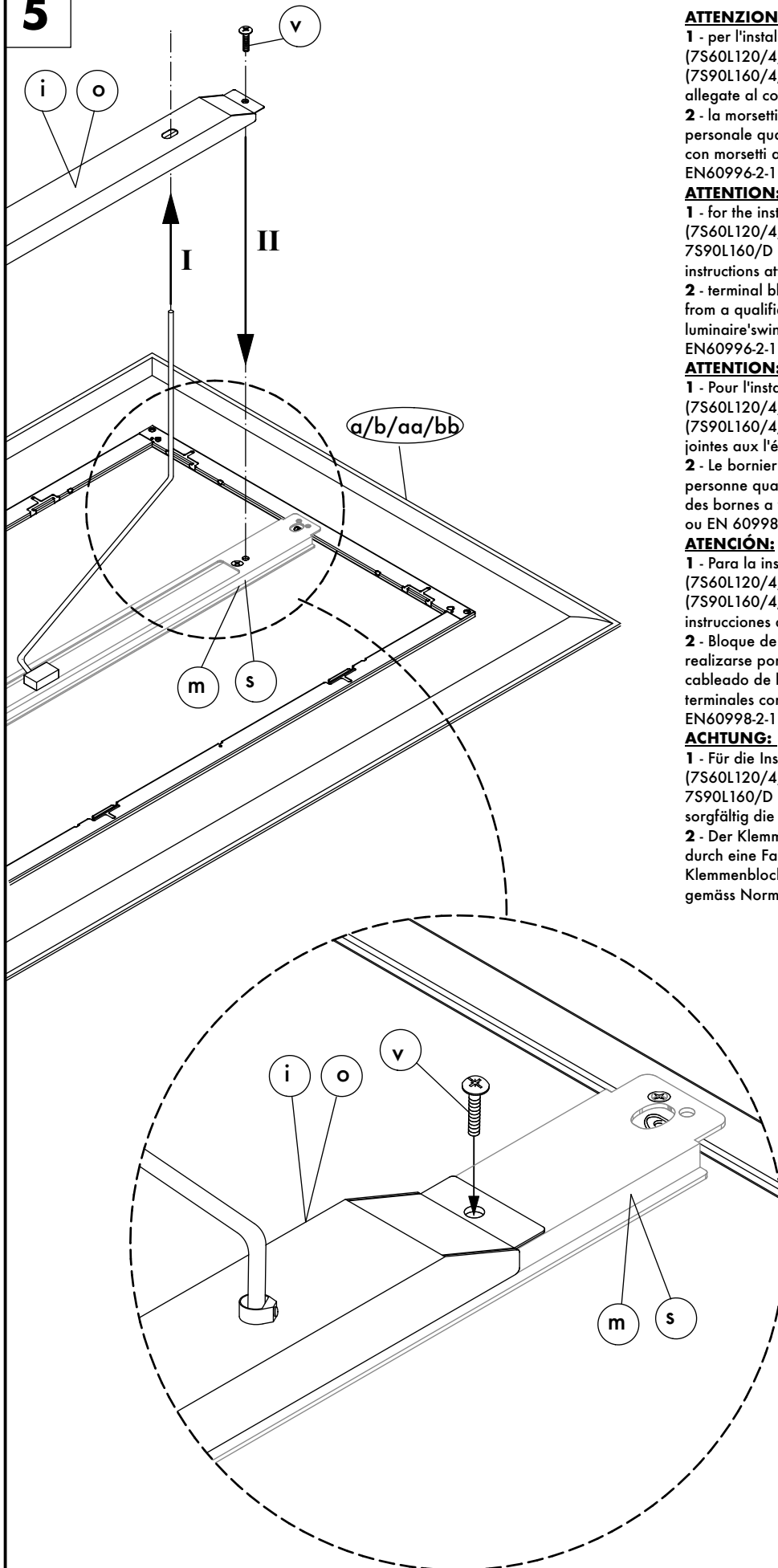
5**ATTENZIONE:**

1 - per l'installazione del codd.7S60L120, 7S60L120/D (7S60L120/4, 7S60L120/D4) e codd.7S90L160, 7S90L160/D (7S90L160/4, 7S90L160/D4) vedere attentamente le istruzioni allegate al corpo illuminante

2 - la morsettiere non è inclusa. L'installazione può richiedere personale qualificato. Utilizzare per il cablaggio una morsettiere con morsetti a vite di sez.2,5mm, conforme alle norme EN60996-2-1 o EN60996-2-2

ATTENTION:

1 - for the installation of codd.7S60L120, 7S60L120/D (7S60L120/4, 7S60L120/D4) and codd.7S90L160, 7S90L160/D (7S90L160/4, 7S90L160/D4), carefully read the instructions attached to the lighting element

2 - terminal block not included. Installation may require advice from a qualified person. For the connection to the luminaire's wiring use with screws size 2,5mm, conform to EN60996-2-1 o EN60996-2-2 standards

ATTENTION:

1 - Pour l'installation de codd.7S60L120, 7S60L120/D (7S60L120/4, 7S60L120/D4) et codd.7S90L160, 7S90L160/D (7S90L160/4, 7S90L160/D4), lisez attentivement les instructions jointes aux l'élément d'éclairage

2 - Le bornier n'est pas inclus. L'installation peut nécessiter d'une personne qualifiée. Utiliser pour le cablage, un bornier avec des bornes à vis de 2,5mm² conforme à la norme EN60998-2-1 ou EN 60998-2-2 standard.

ATENCIÓN:

1 - Para la instalación del codd.7S60L120, 7S60L120/D (7S60L120/4, 7S60L120/D4) y codd.7S90L160, 7S90L160/D (7S90L160/4, 7S90L160/D4), lea cuidadosamente las instrucciones adjuntas al elemento de iluminación

2 - Bloque de terminales no incluido. La instalación debe realizarse por una persona cualificada. Para la conexión del cableado de la luminaria se debe utilizar un bloque de terminales con tornillos de 2,5 mm² conforme a la normativa EN60998-2-1 o EN60998-2-2.

ACHTUNG:

1 - Für die Installation von codd.7S60L120, 7S60L120/D (7S60L120/4, 7S60L120/D4) und codd.7S90L160, 7S90L160/D (7S90L160/4, 7S90L160/D4) lesen Sie bitte sorgfältig die Anweisungen im Scheinwerfer

2 - Der Klemmenblock ist nicht enthalten. Die Installation hat durch eine Fachkraft zu erfolgen. Für die Verkabelung einen Klemmenblock mit Schrauben, für Kabelquerschnitt 2,5mm², gemäß Norm EN60998-2-1 oder EN60998-2-2 verwenden.

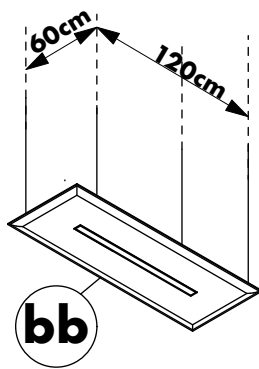
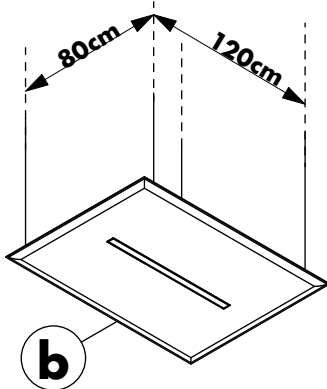
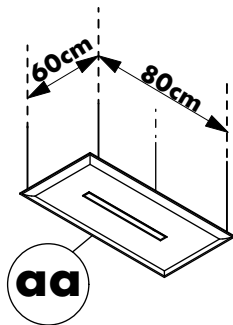
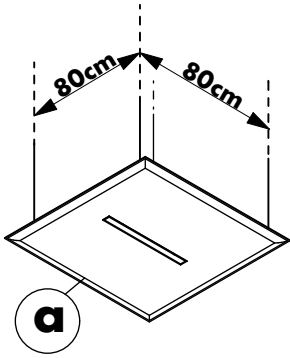
6**7**

codd.
7S401
7SRM10-C

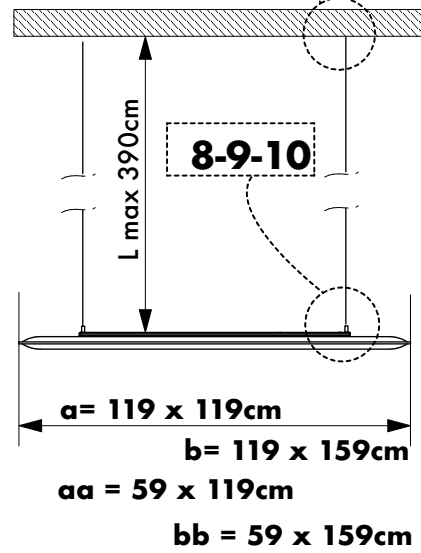
7/A-7/B

7SM6-xx*
OPTIONAL

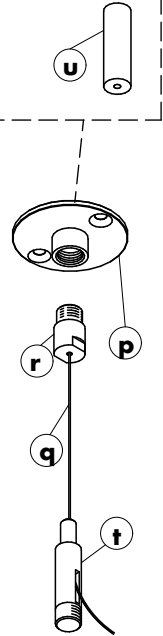
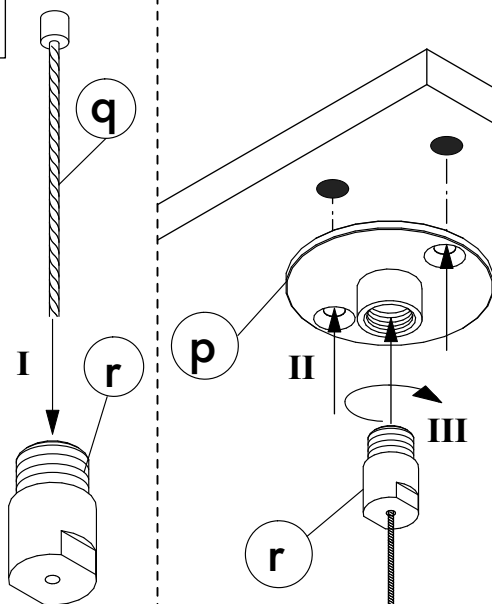
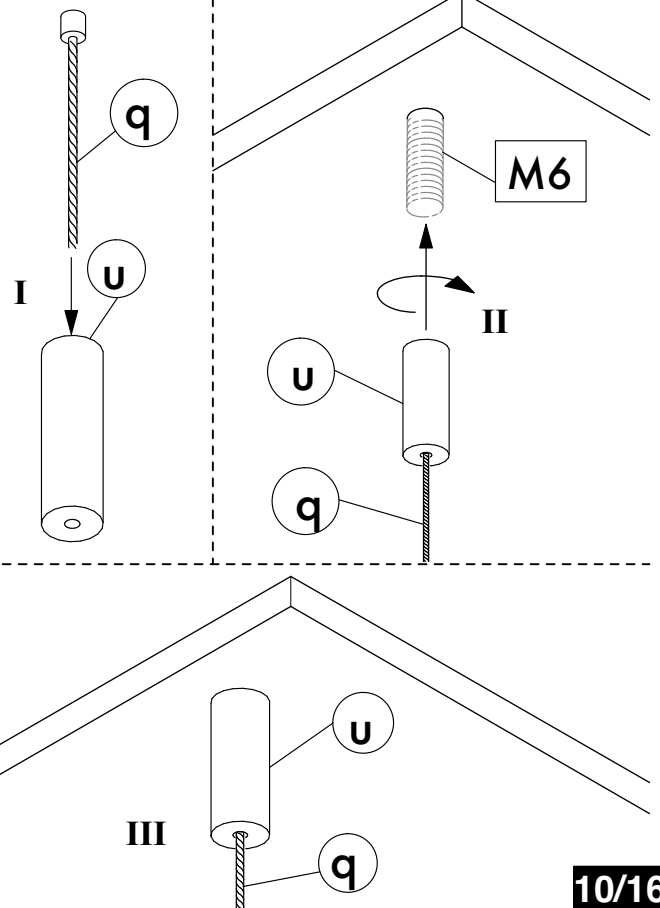
**7/A****7 - optional****10/16**

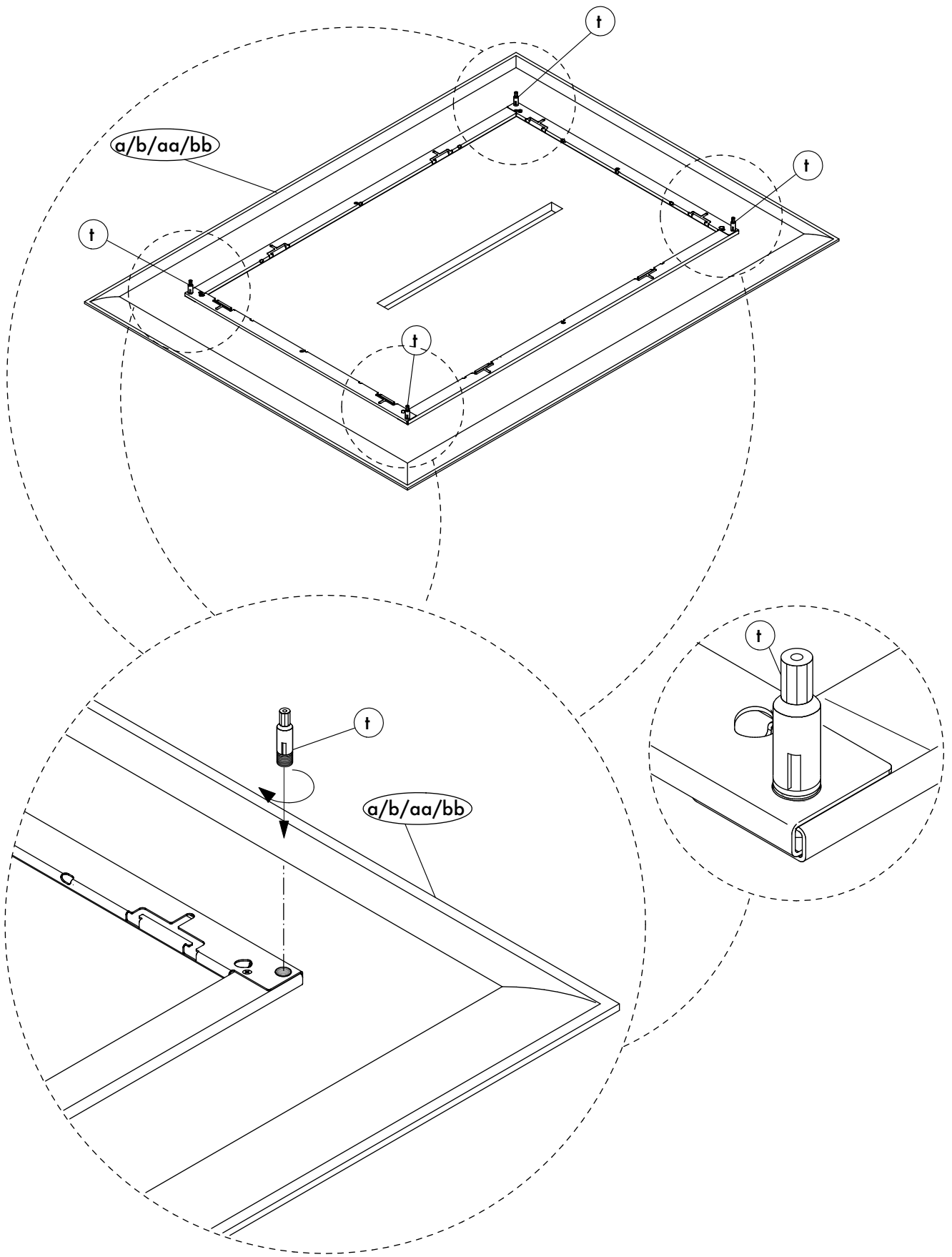

9

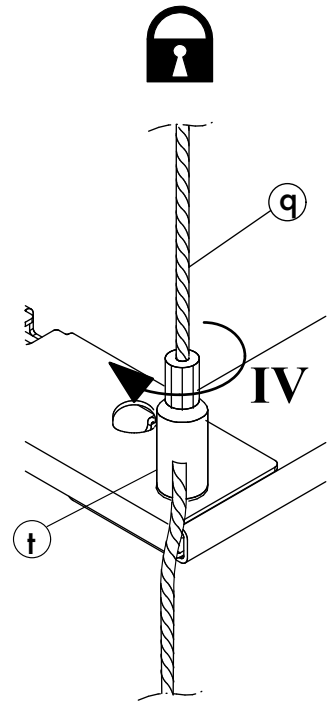
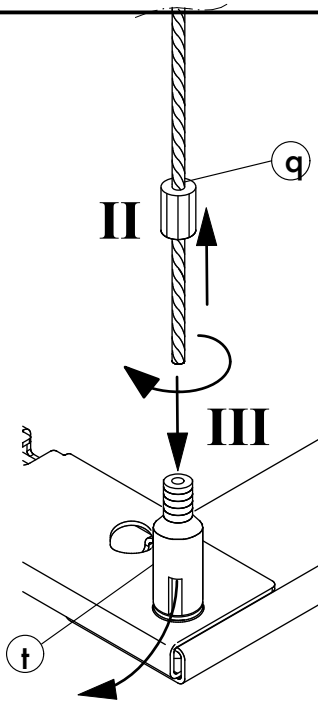
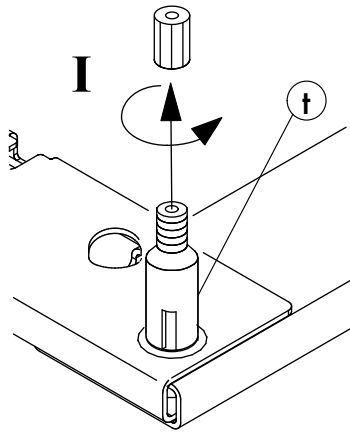

10

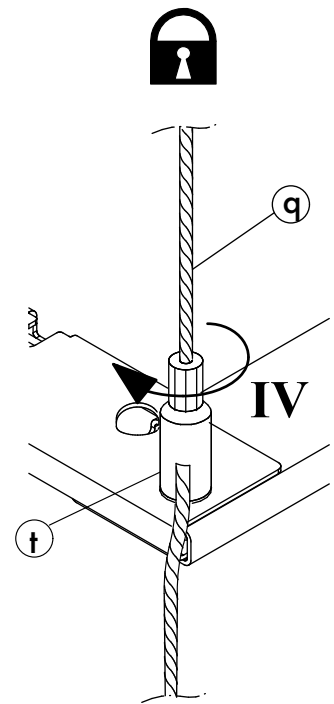
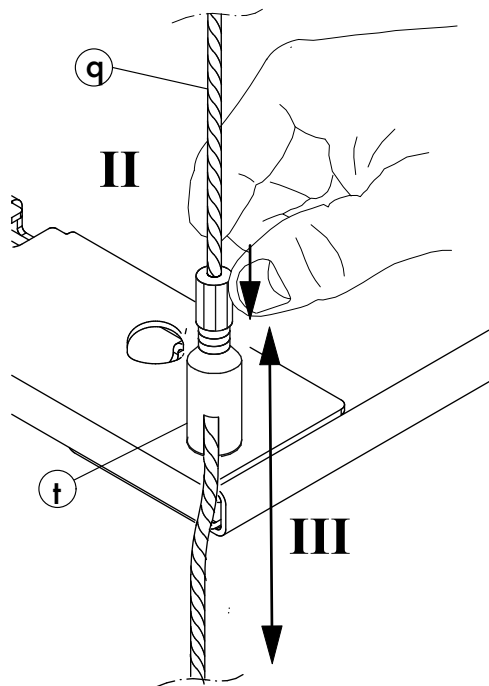
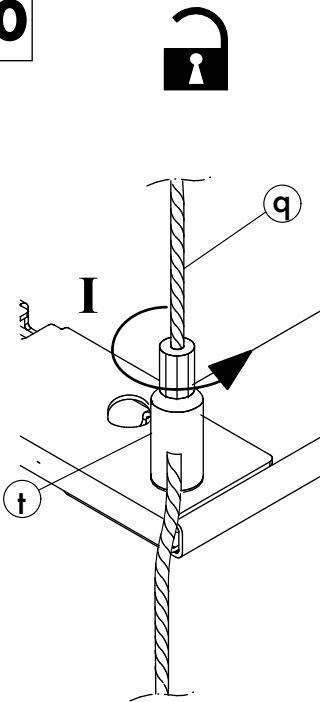

11

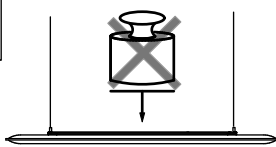

NO



NO

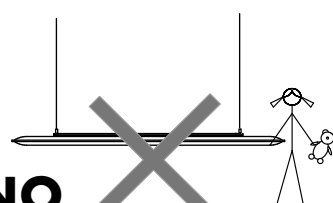

NO



NO

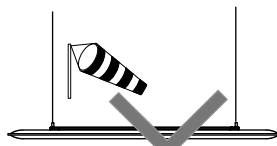

NO



NO

- tenere lontano da fonti di calore
- keep away from heat sources
- tenir loin de sources de chaleur
- mantener alejado de fuentes de calor
- Von Wärmequellen fernhalten

AVVERTENZE!

ISTRUZIONI E INFORMAZIONI PER LA SICUREZZA

prima di procedere al montaggio ed all'installazione del prodotto leggere attentamente le avvertenze di seguito riportate, prestando particolare attenzione ai disegni esplicativi riportati nelle istruzioni per il montaggio. Consultare queste avvertenze ad ogni successivo montaggio e/o installazione del prodotto.

1. Il montaggio e l'installazione del prodotto deve essere effettuato esclusivamente da personale tecnico competente. **Attenzione:** ultimato il montaggio verificare sempre che la struttura realizzata sia idonea al tipo di utenza e/o di utilizzo a cui è destinata. I prodotti non sono comunque idonei all'uso da parte di bambini.
2. Prima di procedere all'installazione è necessario verificare la portanza della superficie su cui verrà collocato il prodotto, di conseguenza utilizzare dispositivi di fissaggio adeguati al tipo di superficie in grado di resistere alle forze generate. **Attenzione:** la superficie deve comunque essere orizzontale, piana, rigida e indeformabile.
3. **Attenzione:** in caso di dubbi sulle modalità di installazione e/o sulla portanza della superficie su cui verrà collocato il prodotto non procedere alla installazione del prodotto.
4. **ATTENZIONE:** per l'installazione del **codd.7S60L120, 7S60L120/D** (7S60L120/4, 7S60L120/D4) e **codd.7S90L160, 7S90L160/D** (7S90L160/4, 7S90L160/D4) vedere attentamente le istruzioni allegate al corpo illuminante
5. **Per la pulizia del pannello (a/b/aa/bb)** utilizzare esclusivamente un prodotto smacchiatore a secco seguendo attentamente le istruzioni riportate sul prodotto utilizzato.
6. Per ulteriori informazioni sulle modalità di installazione del prodotto contattare il rivenditore. Per i casi non contemplati contattare il rivenditore.
7. Accertarsi periodicamente che i sistemi meccanici di serraggio siano opportunamente fissati.

NOTE!

SAFETY INSTRUCTIONS AND INFORMATION

Prior to assembling and installing the unit please read the following notes carefully. Pay particular attention to the drawings in the assembly instructions. Please consult these notes every time the product is assembled and/or installed.

1. The product must only be assembled and installed by competent fitters. **Warning:** once the product has been assembled always check that the structure is suitable for the type of application and/or use to which it will be put. These products are not suitable for use by children.
2. Prior to installation check the load bearing capacity of the surface on which the product is to be fitted, use suitable fixtures according to the type of surface which must be able to withstand the forces generated. **Warning:** the surface must be horizontal, flat, rigid and non-deformable
3. **Warning:** if you have any doubts concerning how to install the product and/or the load bearing capacity of the surface on which it will be fitted, do not fit it.
4. **ATTENTION:** for the installation of **codd.7S60L120, 7S60L120/D** (7S60L120/4, 7S60L120/D4) and **codd.7S90L160, 7S90L160/D** (7S90L160/4, 7S90L160/D4), carefully read the instructions attached to the lighting element
5. **To clean the panel (a/b/aa/bb)** use only a dry stain removal, carefully following the instructions on the product used.
6. For further information on how to install the product, please contact your dealer. For any use different from the ones here shown please contact the dealer.
7. Periodically check that the mechanical tightening systems are properly fixed.

MISES EN GARDE!

INSTRUCTIONS ET INFORMATIONS DE SÉCURITÉ

Avant de procéder au montage et à l'installation du produit, lire attentivement les mises en garde ci-dessous présentées, en faisant particulièrement attention aux dessins explicatifs rapportés dans les instructions de montage. Consulter ces mises en garde lors de chaque montage successif et/ou installation du produit.

1. Le montage et l'installation du produit doivent exclusivement être effectués par un personnel technique compétent. **Attention:** au terme du montage, toujours vérifier si la structure réalisée est appropriée au type d'usagers et/ou d'utilisation auxquels elle est destinée. Les produits ne sont pas destinés aux enfants.
2. Avant de procéder à l'installation, il est nécessaire de vérifier la capacité de charge de la surface sur laquelle le produit sera installé: en conséquence, utiliser les dispositifs de fixation adaptés au type de surface et qui peuvent résister aux forces produites. **Attention:** la surface doit être horizontale, plane, rigide et indeformable.
3. **Attention:** en cas de doute sur les modalités d'installation et/ou sur la capacité de charge de la surface sur laquelle le produit sera installé, ne pas monter le produit.
4. **ATTENTION:** Pour l'installation de **codd.7S60L120, 7S60L120/D** (7S60L120/4, 7S60L120/D4) et **codd.7S90L160, 7S90L160/D** (7S90L160/4, 7S90L160/D4), lisez attentivement les instructions jointes aux l'éléments d'éclairage
5. **Pour le nettoyage du panneau (a/b/aa/bb)** utiliser seulement un détachant à sec en suivant soigneusement les instructions sur le produit utilisé.
6. Pour toute information complémentaire sur les modalités d'installation, contacter le revendeur. Pour emploi différent par rapport à ceux indiqués ici nous vous prions de contacter le revendeur.
7. Vérifier périodiquement que les systèmes mécaniques de serrage soient opportunément fixés.

¡ADVERTENCIAS!

INSTRUCCIONES E INFORMACIÓN DE SEGURIDAD

Antes de realizar el montaje y la instalación del producto leer atentamente las advertencias que se indican a continuación, prestando especial atención a los dibujos y a las instrucciones para el montaje. Consultar estas advertencias cada vez que se monte y/o instale el producto.

1. El montaje y la instalación del producto debe efectuarlo exclusivamente personal técnico competente. **Atención:** una vez acabado el montaje, hay que comprobar siempre que la estructura realizada sea apta para el tipo de servicio y/o uso al que se va a destinar. Los productos no son aptos para niños.
2. Antes de realizar la instalación es necesario controlar la capacidad de carga de la superficie en la que se colocará el producto: por consiguiente, hay que utilizar dispositivos de fijación adecuados para el tipo de superficie capaces de resistir las fuerzas generadas. **Atención:** la superficie debe en cualquier caso ser horizontal, plana, rígida e indeformable.
3. **Atención:** en caso de duda sobre las modalidades de instalación y/o sobre la capacidad de carga de la superficie en la que se vaya a colocar el producto, éste no deberá instalarse.
4. **ATENCIÓN:** Para la instalación del **codd.7S60L120, 7S60L120/D** (7S60L120/4, 7S60L120/D4) y **codd.7S90L160, 7S90L160/D** (7S90L160/4, 7S90L160/D4), lea cuidadosamente las instrucciones adjuntas al elemento de iluminación
5. **Para la limpieza del panel (a/b/aa/bb)** utilizar exclusivamente un producto quitamanchas seco, siguiendo atentamente las instrucciones que aparecen sobre el producto utilizado
6. Para más información sobre las modalidades de instalación del producto, ponerse en contacto con el vendedor. Para cualquier otra utilización por favor consulte con su distribuidor.
7. Verificar periódicamente que los sistemas mecánicos de cierres sean correctamente fijados.

WICHTIG!

SICHERHEITSHINWEISE UND INFORMATIONEN

Vor der Montage und der Aufstellung des Produktes folgende Anleitungen sorgfältig lesen und dabei die Einbauzeichnungen, die in den Montageanleitungen zu finden sind genau beachten. Die validen Angaben bei jeder Montage und/oder Aufstellung des Produktes nachsehen

1. Die Montage und die Aufstellung des Produktes dürfen ausschließlich von erfahrenem Fachpersonal ausgeführt werden. **Vorsicht:** sich nach der Montage immer vergewissern, dass die aufgestellte Struktur ihren Verwendungszwecken und/oder dem Benutzerkreis entspricht. Est ist aber dabei nicht zu vergessen, daß der Gebrauch dieser Produkte Kindern untersagt ist.
2. Vor jeglicher Montage die Oberfläche, an der das Produkt montiert werden soll, auf ihre Tragfähigkeit prüfen und passende Befestigungsmittel welche die erzeugten Kräfte aushalten können je nach Art der Oberfläche benutzen. **Vorsicht:** die Bodenfläche immer waagrecht, flach, steif und unverformbar sein.
3. Wichtig: bestehen Zweifel über die Einbaumodalitäten und/oder über die Tragfähigkeit der betroffenen Oberfläche, Produkt nicht aufstellen.
4. Für die Installation von **codd.7S60L120, 7S60L120/D** (7S60L120/4, 7S60L120/D4) und **codd.7S90L160, 7S90L160/D** (7S90L160/4, 7S90L160/D4) lesen Sie bitte sorgfältig die Anweisungen im Scheinwerfer
5. **Zur Reinigung der Akustikpaneel (a/b/aa/bb)** darf nur Schaumreiniger verwendet werden, wobei die Anleitung auf dem gewählten Produkt genau zu befolgen ist.
6. Für weitere Angaben über die Aufstellungsmodalitäten wenden Sie sich bitte an Ihren Wiederverkäufer. Für alle Anlagen, die nicht aufgeführt sind, kontaktieren Sie bitte vor dem Einbau den Fachhandelspartner.
7. Kontrollieren Sie periodisch die mechanische Befestigung.

MOD. 530 / L0

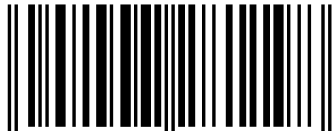

8 002447 281198

Caimi
BREVETTI

OVERSIZE LUX

Design: Caimi Lab

* (xx = variante colore, colour alternative, variante couleur, variante color, Farbe Variante)

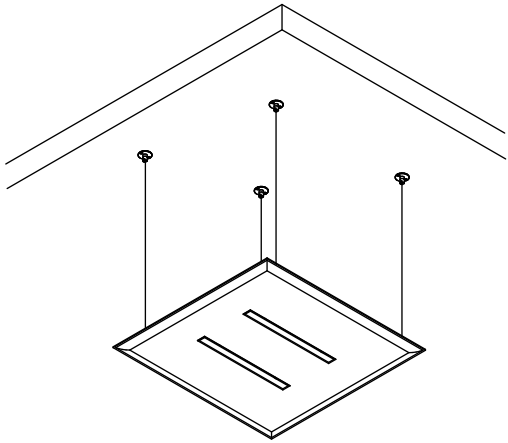

codd.7OL12/2L6-xx*
7OL12/2D6-xx*

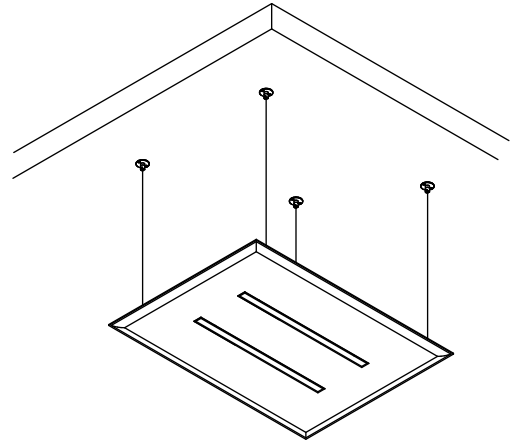

codd.7OL12/2L9-xx*
7OL12/2D9-xx*

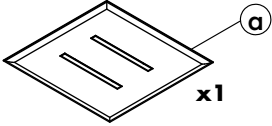
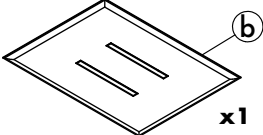
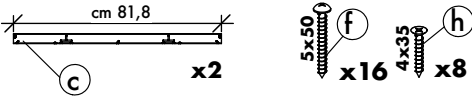
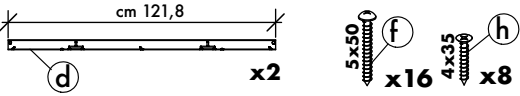
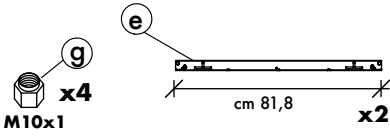
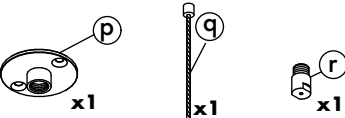

ISTRUZIONI DI MONTAGGIO
ASSEMBLY INSTRUCTIONS
NOTICE DE MONTAGE
INSTRUCCIONES DE MONTAJE
MONTAGEANLEITUNG

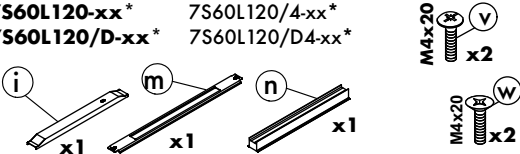
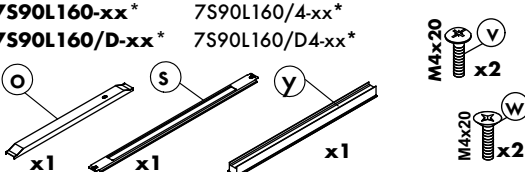
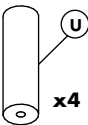
	7OL12/2L6-xx* 7OL12/2D6-xx*	7OL12/2L9-xx* 7OL12/2D9-xx*
7S1212/L6-xx* 	x1	
7S1216/L9-xx* 	x1	x1
7S340/2 	x1	
7S340/3 	x1	x1
7S340/1 	x1	x1
7S401 	x4	x4
7SRM10-C 	x4	x4
7S60L120-xx* 7S60L120/4-xx* 7S60L120/D-xx* 7S60L120/D4-xx* 	x2	
7S90L160-xx* 7S90L160/4-xx* 7S90L160/D-xx* 7S90L160/D4-xx* 	x2	x2
7SM6 	OPTIONAL	OPTIONAL

7SL/R2F-xx*
OPTIONAL

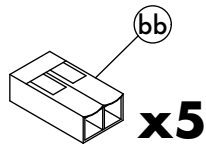
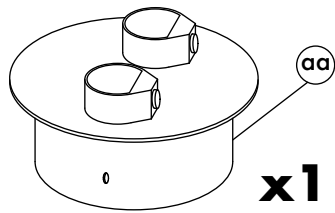

ATTENZIONE: per l'installazione vedere attentamente le istruzioni allegate al corpo illuminante

ATTENTION: for the installation carefully read the instructions attached to the lighting element

ATTENTION: Pour l'installation lisez attentivement les instructions jointes aux l'élément d'éclairage

ATENCIÓN: Para la instalación lea cuidadosamente las instrucciones adjuntas all' elemento de iluminación

ACHTUNG: Für die Installation lesen Sie bitte sorgfältig die Anweisungen im Scheinwerfer

70L12/2L6-xx*
70L12/2D6-xx*

70L12/2L9-xx*
70L12/2D9-xx*

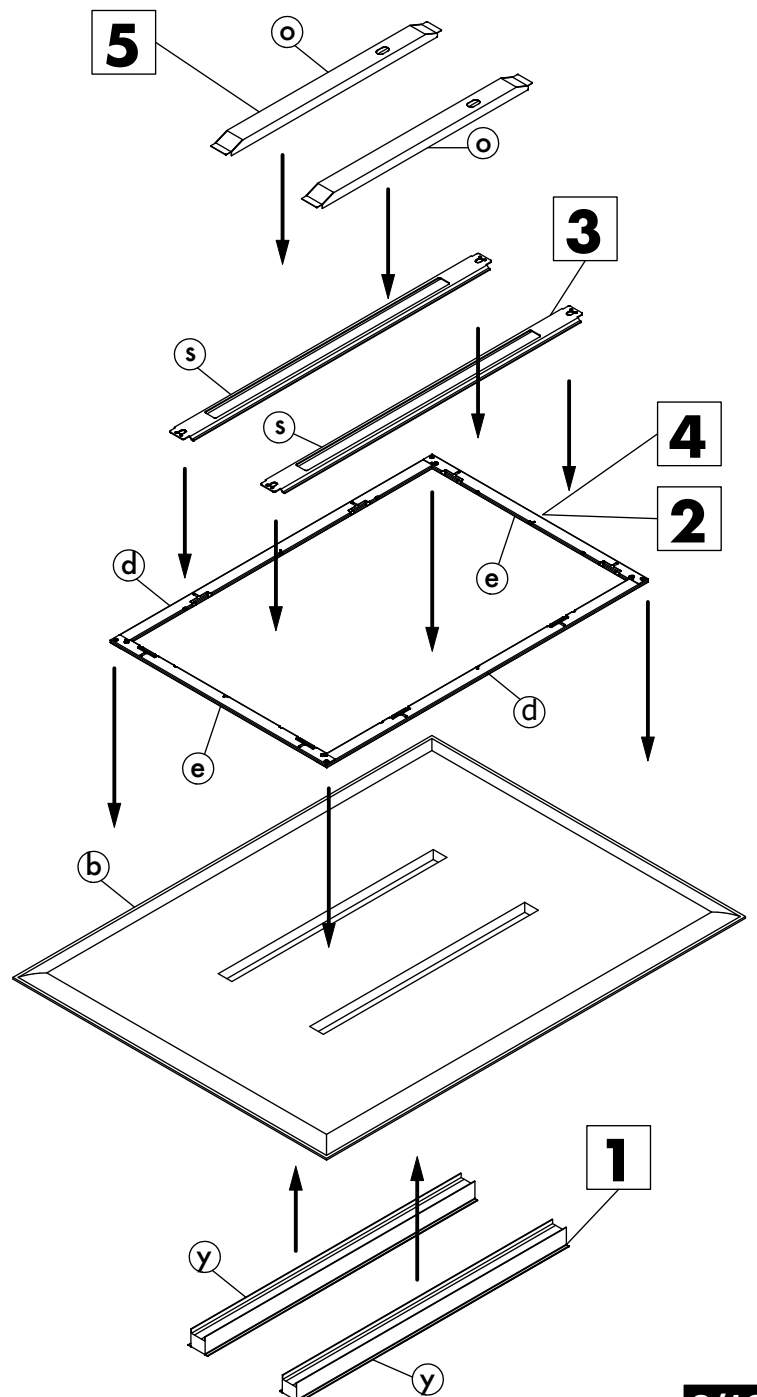
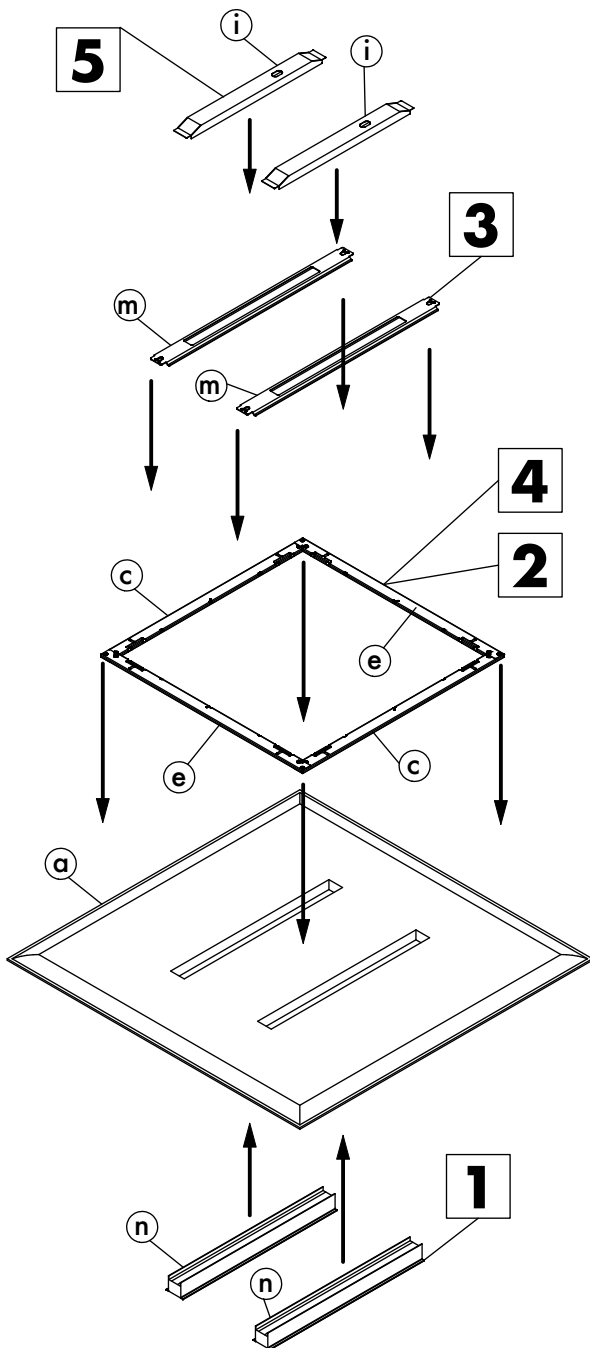

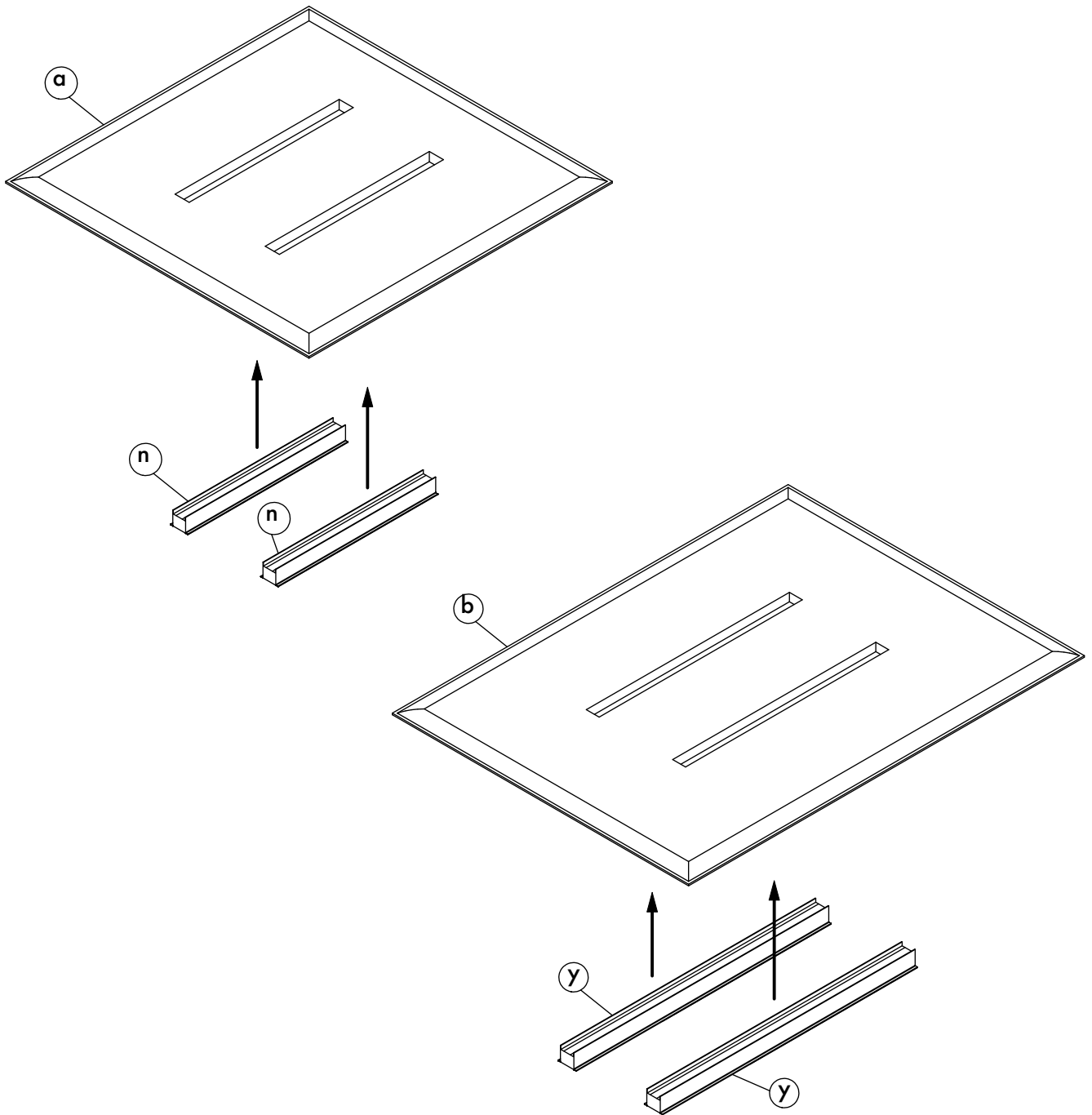
**ATTENZIONE:**

1 - Per l'installazione del codd.7S60L120, 7S60L120/D (7S60L120/4, 7S60L120/D4) e codd.7S90L160, 7S90L160/D (7S90L160/4, 7S90L160/D4) vedere attentamente le istruzioni allegate al corpo illuminante

2 - la morsetteria non è inclusa. L'installazione può richiedere personale qualificato. Utilizzare per il cablaggio una morsetteria con morsetti a vite di sez.2,5mm, conforme alle norme EN60996-2-1 o EN60996-2-2

ATTENTION:

1 - For the installation of codd.7S60L120, 7S60L120/D (7S60L120/4, 7S60L120/D4) and codd.7S90L160, 7S90L160/D (7S90L160/4, 7S90L160/D4), carefully read the instructions attached to the lighting element

2 - terminal block not included. Installation may require advice from a qualified person. For the connection to the luminaire's wiring use with screws size 2,5mm, conform to EN60996-2-1 o EN60996-2-2 standards.

ATTENTION:

1 - Pour l'installation de codd.7S60L120, 7S60L120/D (7S60L120/4, 7S60L120/D4) et codd.7S90L160, 7S90L160/D (7S90L160/4, 7S90L160/D4), lisez attentivement les instructions jointes aux l'élément d'éclairage

2 - Le bornier n'est pas inclus. L'installation peut nécessiter d'une personne qualifiée. Utiliser pour le câblage, un bornier avec des bornes à vis de 2,5mm² conforme à la norme EN60998-2-1 ou EN 60998-2-2 standard.

ATENCIÓN:

1 - Para la instalación del codd.7S60L120, 7S60L120/D (7S60L120/4, 7S60L120/D4) y codd.7S90L160, 7S90L160/D (7S90L160/4, 7S90L160/D4), lea cuidadosamente las instrucciones adjuntas al elemento de iluminación

2 - Bloque de terminales no incluido. La instalación debe realizarse por una persona cualificada. Para la conexión del cableado de la luminaria se debe utilizar un bloque de terminales con tornillos de 2,5 mm² conforme a la normativa EN60998-2-1 o EN60998-2-2.

ACHTUNG:

1 - Für die Installation von codd.7S60L120, 7S60L120/D (7S60L120/4, 7S60L120/D4) und codd.7S90L160, 7S90L160/D (7S90L160/4, 7S90L160/D4) lesen Sie bitte sorgfältig die Anweisungen im Scheinwerfer

2 - Der Klemmenblock ist nicht enthalten. Die Installation hat durch eine Fachkraft zu erfolgen. Für die Verkabelung einen Klemmenblock mit Schrauben, für Kabelquerschnitt 2,5mm², gemäß

Norm EN60998-2-1 oder EN60998-2-2 verwenden.

2

- Posizionare il telaio sul pannello senza fissarlo

- Position the frame on panel without fixing

- Positionnez le cadre sur panneau sans fixation

- Coloque el marco en el Panel sin fijarlo

- Standpunkt-Frame auf Panel ohne Fixierung

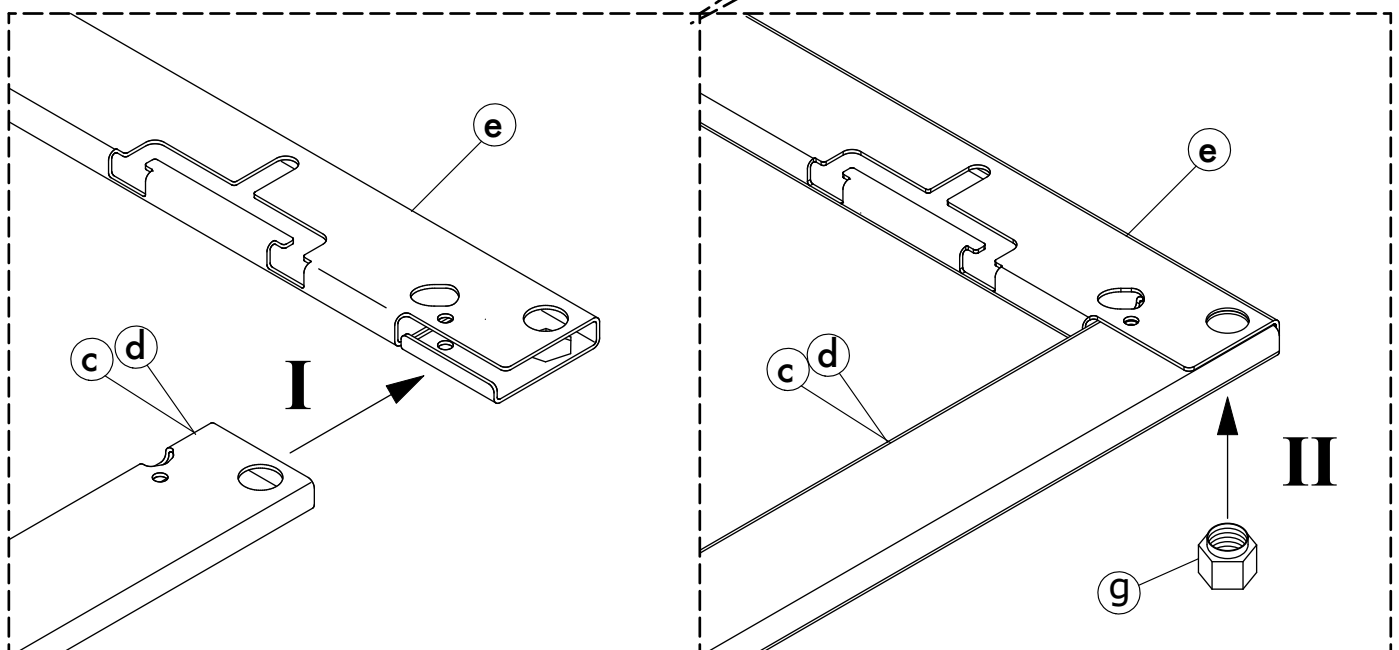
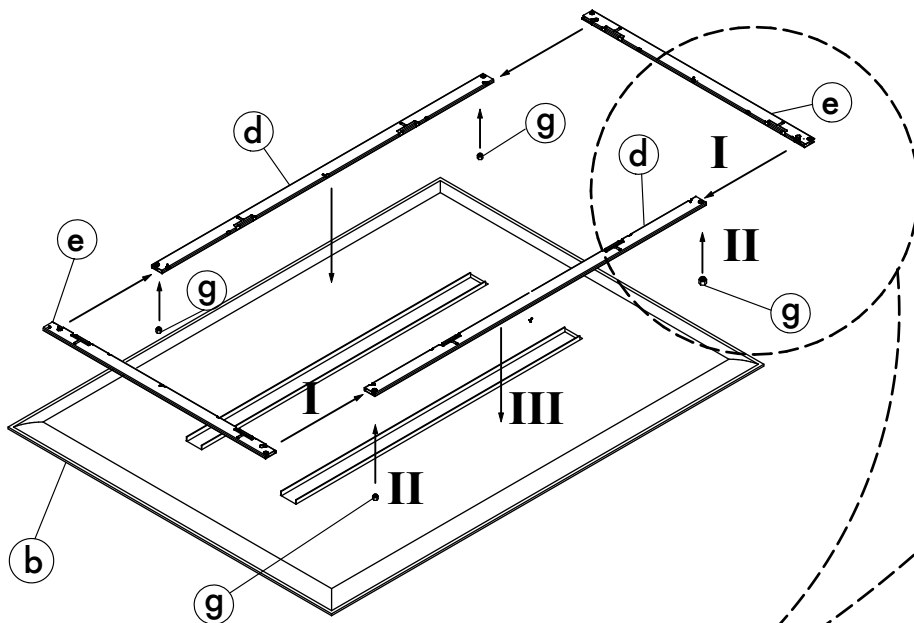
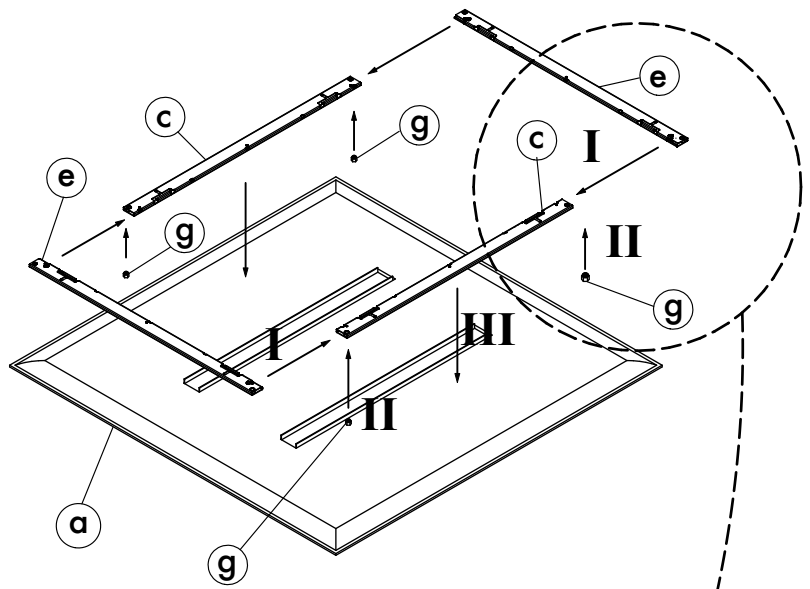

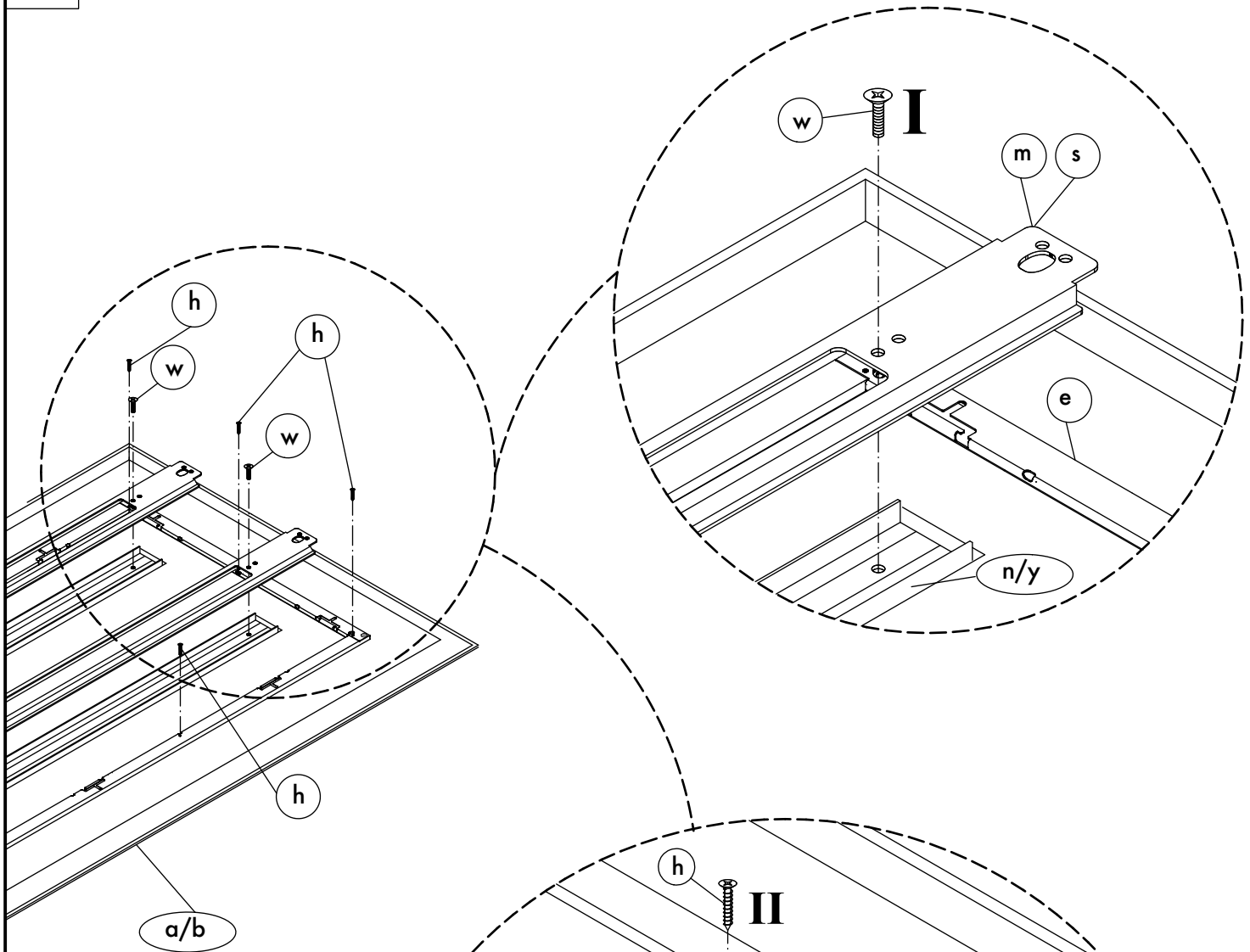

a/b

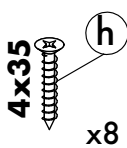

ATTENZIONE: Avvitare tassativamente tutte le viti (**h**)

WARNING: It is compulsory to screw all the screws (**h**)

ATTENTION: Imperatif serrer toutes les vis (**h**)

ATENCIÓN: Apretar obligatoriamente todos los tornillos (**h**)

ACHTUNG: Es müssen unbedingt alle Schrauben (**h**)

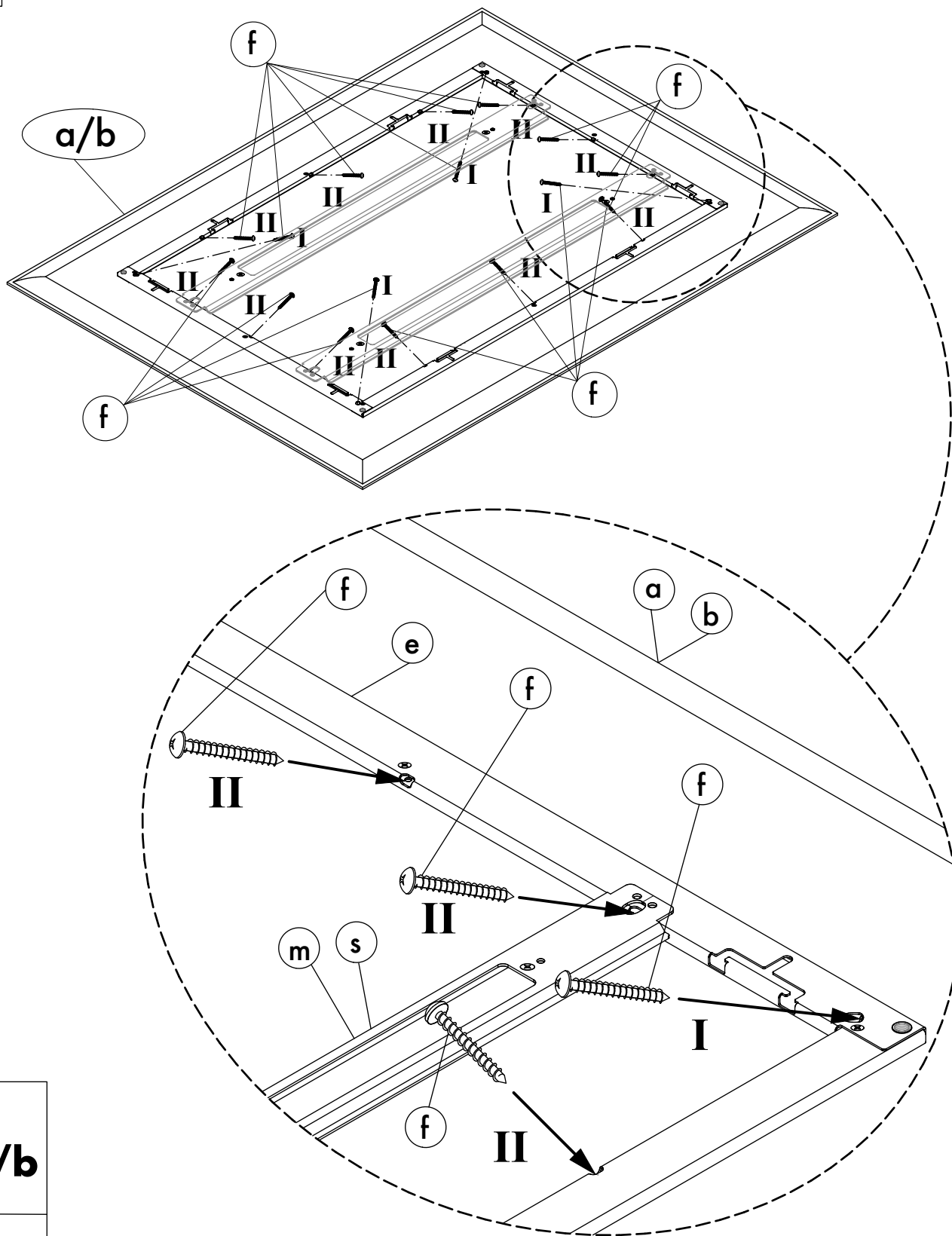

a/b



x16

ATTENZIONE: Avvitare tassativamente tutte le viti (f)

WARNING: It is compulsory to screw the screws (f)

ATTENTION: Imperatif serrer toutes les vis (f)

ATENCIÓN: Apretar obligatoriamente todos los tornillos (f)

ACHTUNG: Es müssen unbedingt alle Schrauben (f)

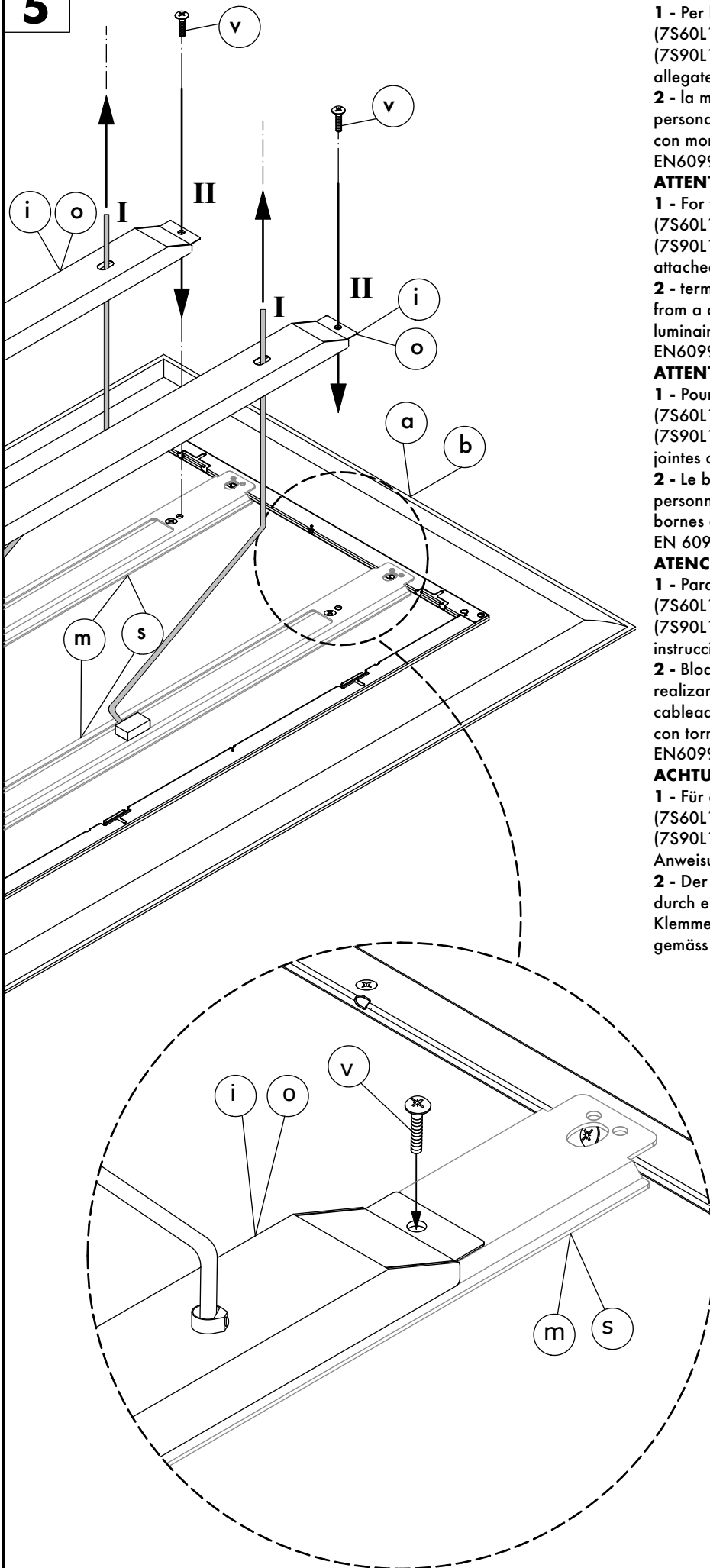
5**ATTENZIONE:**

1 - Per l'installazione del codd.7S60L120, 7S60L120/D (7S60L120/4, 7S60L120/D4) e codd.7S90L160, 7S90L160/D (7S90L160/4, 7S90L160/D4) vedere attentamente le istruzioni allegate al corpo illuminante

2 - la morsetti non è inclusa. L'installazione può richiedere personale qualificato. Utilizzare per il cablaggio una morsetti con morsetti a vite di sez.2,5mm, conforme alle norme EN60996-2-1 o EN60996-2-2

ATTENTION:

1 - For the installation of codd.7S60L120, 7S60L120/D (7S60L120/4, 7S60L120/D4) and codd.7S90L160, 7S90L160/D (7S90L160/4, 7S90L160/D4), carefully read the instructions attached to the lighting element

2 - terminal block not included. Installation may require advice from a qualified person. For the connection to the luminaire'swining usa with screws size 2,5mm, conform to EN60996-2-1 o EN60996-2-2 standards.

ATTENTION:

1 - Pour l'installation de codd.7S60L120, 7S60L120/D (7S60L120/4, 7S60L120/D4) et codd.7S90L160, 7S90L160/D (7S90L160/4, 7S90L160/D4), lisez attentivement les instructions jointes aux l'élément d'éclairage

2 - Le bornier n'est pas inclus. L'installation peut nécessiter d'une personne qualifiée. Utiliser pour le cablage, un bornier avec des bornes a vis de 2,5mm² conforme à la norme EN60998-2-1 ou EN 60998-2-2 standard.

ATENCIÓN:

1 - Para la instalación del codd.7S60L120, 7S60L120/D (7S60L120/4, 7S60L120/D4) y codd.7S90L160, 7S90L160/D (7S90L160/4, 7S90L160/D4), lea cuidadosamente las instrucciones adjuntas all' elemento de iluminación

2 - Bloque de terminales no incluido. La instalación debe realizarse por una persona cualificada. Para la conexión del cableado de la luminaria se debe utilizar un bloque de terminales con tornillos de 2,5 mm² conforme a la normativa EN60998-2-1 o EN60998-2-2.

ACHTUNG:

1 - Für die Installation von codd.7S60L120, 7S60L120/D (7S60L120/4, 7S60L120/D4) und codd.7S90L160, 7S90L160/D (7S90L160/4, 7S90L160/D4) lesen Sie bitte sorgfältig die Anweisungen im Scheinwerfer

2 - Der Klemmenblock ist nicht enthalten. Die Installation hat durch eine Fachkraft zu erfolgen. Für die Verkabelung einen Klemmenblock mit Schrauben, für Kabelquerschnitt 2,5mm², gemäss Norm EN60998-2-1 oder EN60998-2-2 verwenden.

6

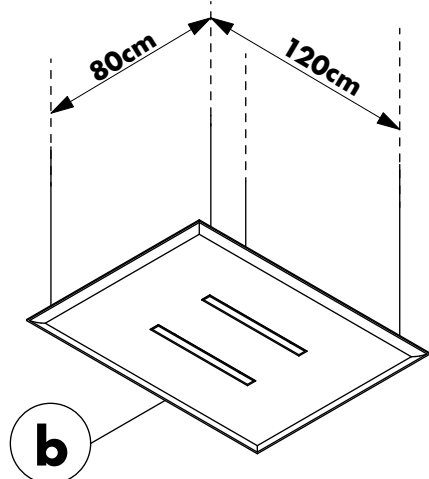
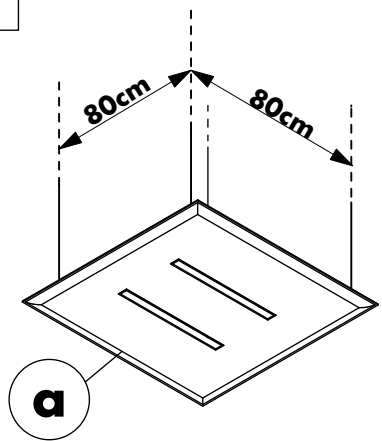

7

codd.
7S401+7SRM10-C

7/A-7/B

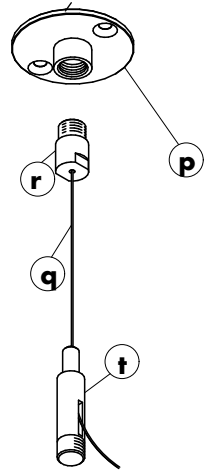
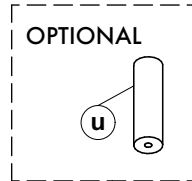
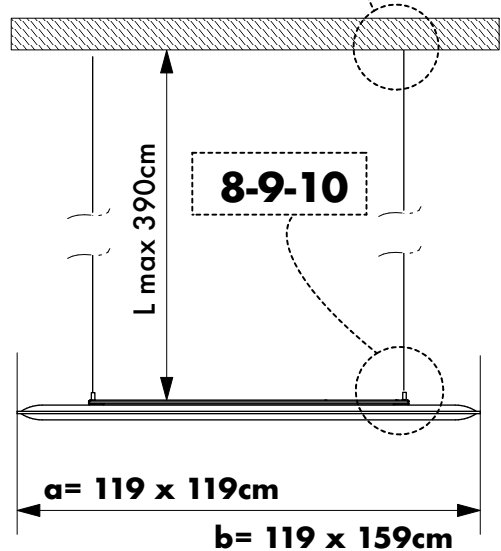

7/A

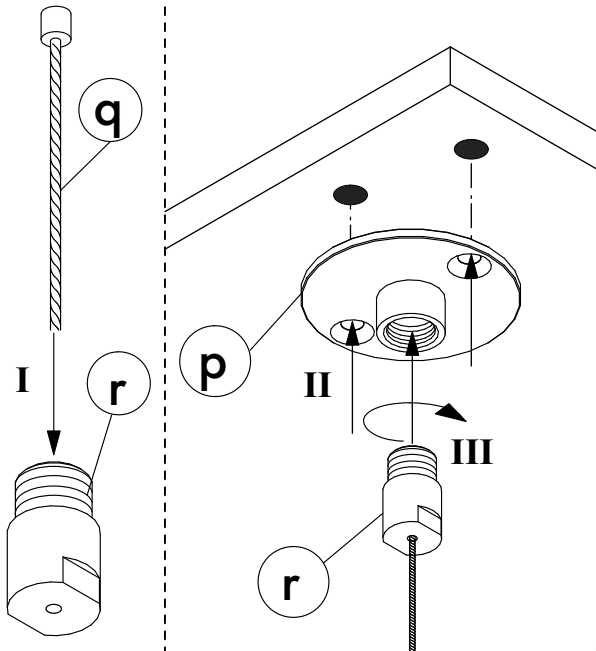

7/B

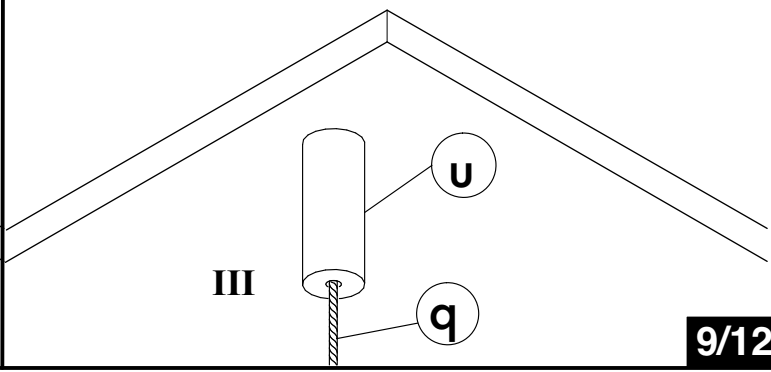
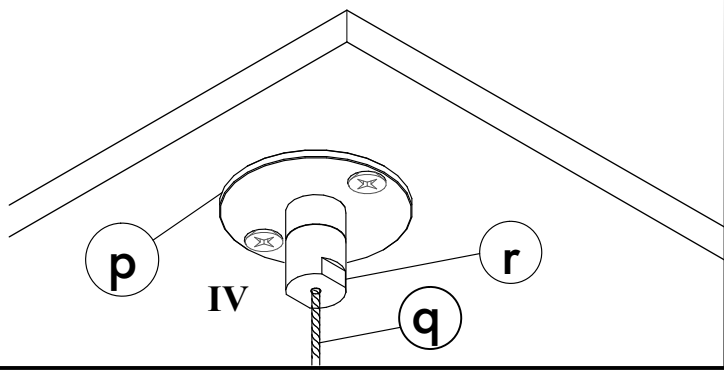
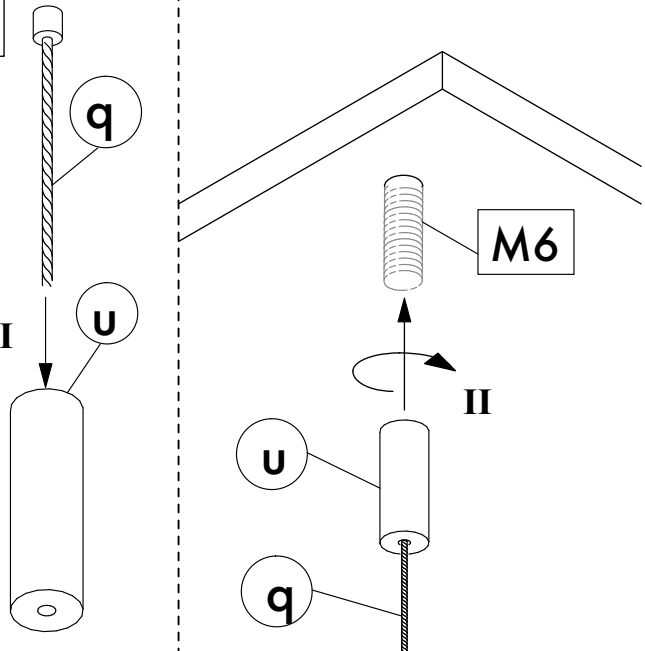

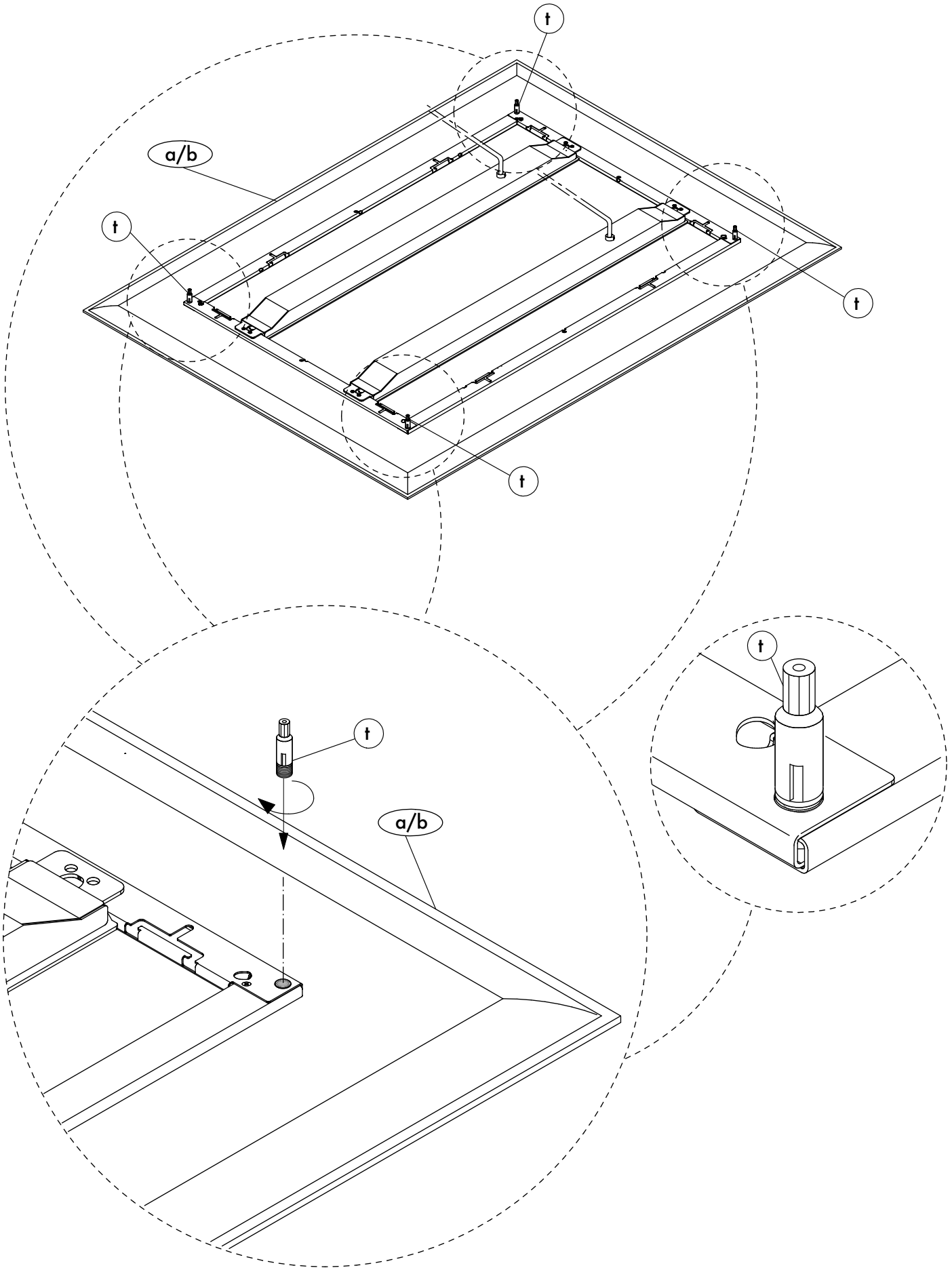

9

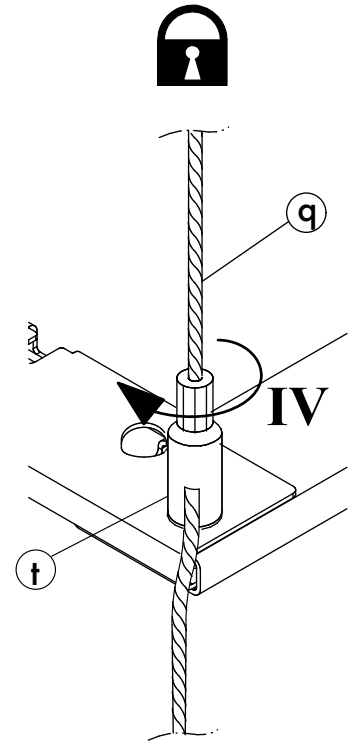
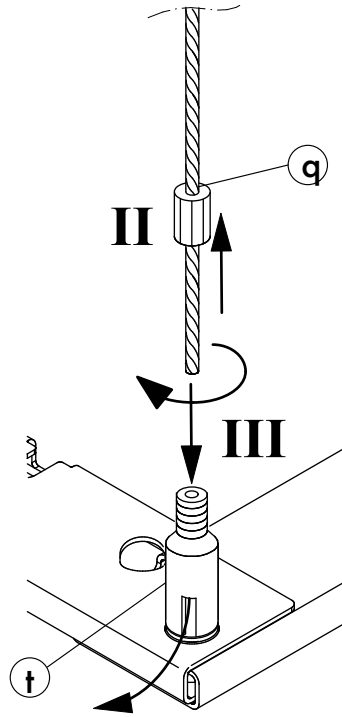
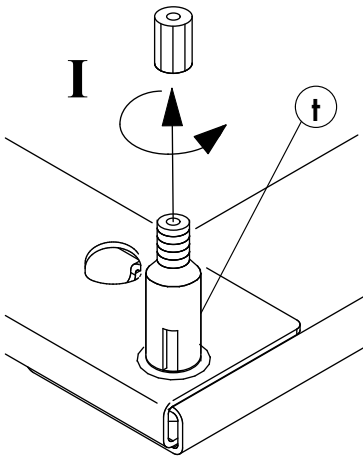

10

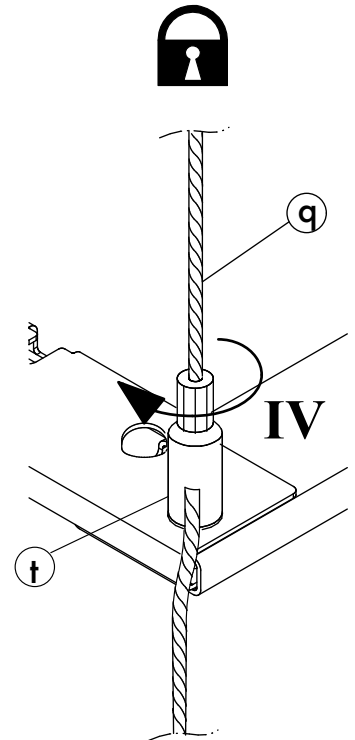
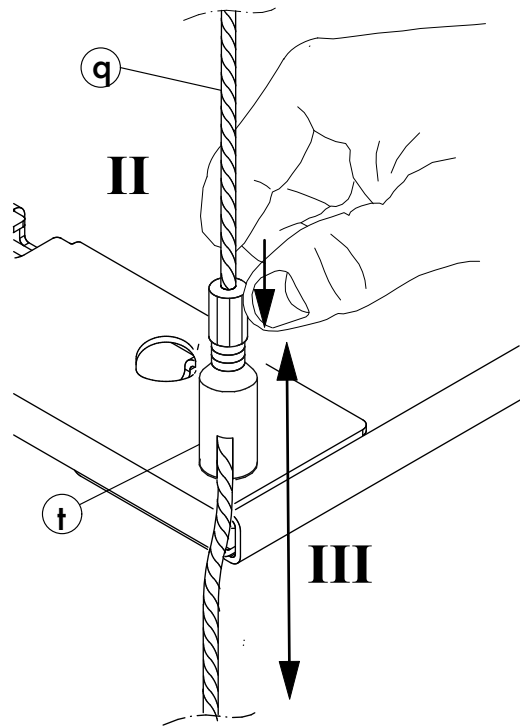
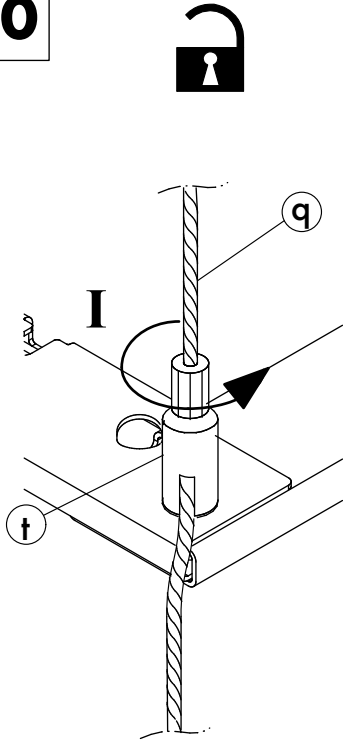

11

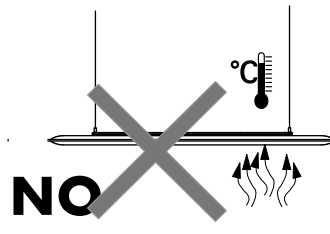
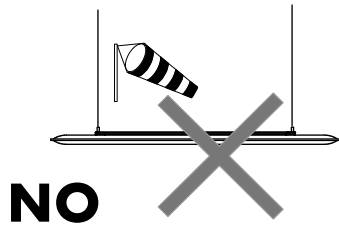
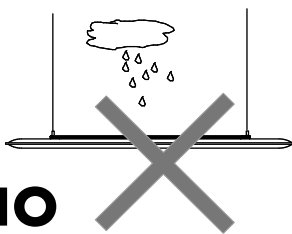
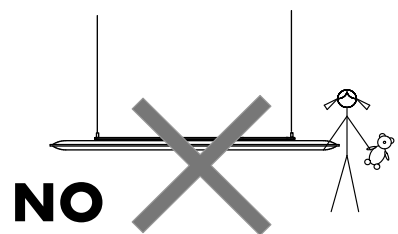
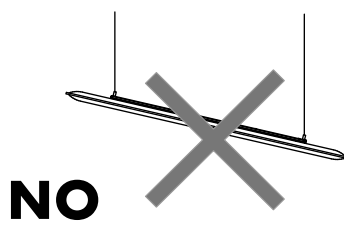
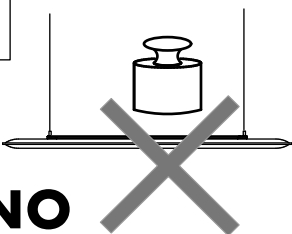

- tenere lontano da fonti di calore
- keep away from heat sources
- tenir loin de sources de chaleur
- mantener alejado de fuentes de calor
- Von Wärmequellen fernhalten

AVVERTENZE!

ISTRUZIONI E INFORMAZIONI PER LA SICUREZZA

prima di procedere al montaggio ed all'installazione del prodotto leggere attentamente le avvertenze di seguito riportate, prestando particolare attenzione ai disegni esplicativi riportati nelle istruzioni per il montaggio. Consultare queste avvertenze ad ogni successivo montaggio e/o installazione del prodotto.

1. Il montaggio e l'installazione del prodotto deve essere effettuato esclusivamente da personale tecnico competente. **Attenzione:** ultimato il montaggio verificare sempre che la struttura realizzata sia idonea al tipo di utenza e/o di utilizzo a cui è destinata. I prodotti non sono comunque idonei all'uso da parte di bambini.
2. Prima di procedere all'installazione è necessario verificare la portanza della superficie su cui verrà collocato il prodotto, di conseguenza utilizzare dispositivi di fissaggio adeguati al tipo di superficie in grado di resistere alle forze generate. **Attenzione:** la superficie deve comunque essere orizzontale, piana, rigida e indeformabile.
3. **Attenzione:** in caso di dubbi sulle modalità di installazione e/o sulla portanza della superficie su cui verrà collocato il prodotto non procedere alla installazione del prodotto.
4. **ATTENZIONE:** per l'installazione del **codd.7S60L120, 7S60L120/D** (7S60L120/4, 7S60L120/D4) e **codd.7S90L160, 7S90L160/D** (7S90L160/4, 7S90L160/D4) vedere attentamente le istruzioni allegate al corpo illuminante
5. **Per la pulizia del pannello (a)** utilizzare esclusivamente un prodotto smacchiatore a secco seguendo attentamente le istruzioni riportate sul prodotto utilizzato.
6. Per ulteriori informazioni sulle modalità di installazione del prodotto contattare il rivenditore. Per i casi non contemplati contattare il rivenditore.
7. Accertarsi periodicamente che i sistemi meccanici di serraggio siano opportunamente fissati.

NOTE!

SAFETY INSTRUCTIONS AND INFORMATION

Prior to assembling and installing the unit please read the following notes carefully. Pay particular attention to the drawings in the assembly instructions. Please consult these notes every time the product is assembled and/or installed.

1. The product must only be assembled and installed by competent fitters. **Warning:** once the product has been assembled always check that the structure is suitable for the type of application and/or use to which it will be put. These products are not suitable for use by children.
2. Prior to installation check the load bearing capacity of the surface on which the product is to be fitted, use suitable fixtures according to the type of surface which must be able to withstand the forces generated. **Warning:** the surface must be horizontal, flat, rigid and non-deformable
3. **Warning:** if you have any doubts concerning how to install the product and/or the load bearing capacity of the surface on which it will fitted, do not fit it.
4. **ATTENTION:** for the installation of **codd.7S60L120, 7S60L120/D** (7S60L120/4, 7S60L120/D4) and **codd.7S90L160, 7S90L160/D** (7S90L160/4, 7S90L160/D4), carefully read the instructions attached to the lighting element
5. **To clean the panel (a)** use only a dry stain removal, carefully following the instructions on the product used.
6. For further information on how to install the product, please contact your dealer. For any use different from the ones here shown please contact the dealer.
7. Periodically check that the mechanical tightening systems are properly fixed.

MISES EN GARDE!

INSTRUCTIONS ET INFORMATIONS DE SÉCURITÉ

Avant de procéder au montage et à l'installation du produit, lire attentivement les mises en garde ci-dessous présentées, en faisant particulièrement attention aux dessins explicatifs rapportés dans les instructions de montage. Consulter ces mises en garde lors de chaque montage successif et/ou installation du produit.

1. Le montage et l'installation du produit doivent exclusivement être effectués par un personnel technique compétent. **Attention:** au terme du montage, toujours vérifier si la structure réalisée est appropriée au type d'usagers et/ou d'utilisation auxquels elle est destinée. Les produits ne sont pas destinés aux enfants.
2. Avant de procéder à l'installation, il est nécessaire de vérifier la capacité de charge de la surface sur laquelle le produit sera installé : en conséquence, utiliser les dispositifs de fixation adaptés au type de surface et qui peuvent résister aux forces produites. **Attention :** la surface doit être horizontale, plane, rigide et indeformable.
3. **Attention:** en cas de doute sur les modalités d'installation et/ou sur la capacité de charge de la surface sur laquelle le produit sera installé, ne pas monter le produit.
4. **ATTENTION:** Pour l'installation de **codd.7S60L120, 7S60L120/D** (7S60L120/4, 7S60L120/D4) et **codd.7S90L160, 7S90L160/D** (7S90L160/4, 7S90L160/D4), lisez attentivement les instructions jointes aux l'élément d'éclairage
5. **Pour le nettoyage du panneau (a)** utiliser seulement un détachant à sec en suivant soigneusement les instructions sur le produit utilisé.
6. Pour toute information complémentaire sur les modalités d'installation, contacter le revendeur. Pour emploi différent par rapport à ceux indiqués ici nous vous prions de contacter le revendeur.
7. Vérifier périodiquement que les systèmes mécaniques de serrage soient opportunément fixés.

¡ADVERTENCIAS!

INSTRUCCIONES E INFORMACIÓN DE SEGURIDAD

Antes de realizar el montaje y la instalación del producto leer atentamente las advertencias que se indican a continuación, prestando especial atención a los dibujos y a las instrucciones para el montaje. Consultar estas advertencias cada vez que se monte y/o instale el producto .

1. El montaje y la instalación del producto debe efectuarlo exclusivamente personal técnico competente. **Atención:** una vez acabado el montaje, hay que comprobar siempre que la estructura realizada sea apta para el tipo de servicio y/o uso al que se va a destinar. Los productos no son aptos para niños.
2. Antes de realizar la instalación es necesario controlar la capacidad de carga de la superficie en la que se colocará el producto : por consiguiente, hay que utilizar dispositivos de fijación adecuados para el tipo de superficie capaces de resistir las fuerzas generadas. **Atención:** la superficie debe en cualquier caso ser horizontal, plana, rígida e indeformable.
3. **Atención:** en caso de duda sobre las modalidades de instalación y/o sobre la capacidad de carga de la superficie en la que se vaya a colocar el producto, éste no deberá instalarse.
4. **ATENCIÓN:** Para la instalación del **codd.7S60L120, 7S60L120/D** (7S60L120/4, 7S60L120/D4) y **codd.7S90L160, 7S90L160/D** (7S90L160/4, 7S90L160/D4), lea cuidadosamente las instrucciones adjuntas al elemento de iluminación
5. **Para la limpieza del panel (a)** utilizar exclusivamente un producto quitamanchas en seco, siguiendo atentamente las instrucciones que aparecen sobre el producto utilizado
6. Para más información sobre las modalidades de instalación del producto, ponerse en contacto con el vendedor. Para cualquier otra utilización por favor consulte con su distribuidor.
7. Verificar periódicamente que los sistemas mecánicos de cierres sean correctamente fijados.

WICHTIG!

SICHERHEITSHINWEISE UND INFORMATIONEN

Vor der Montage und der Aufstellung des Produktes folgende Anleitungen sorgfältig lesen und dabei die Einbauezeichnungen, die in den Montageanleitungen zu finden sind genau beachten. Die wichtigen Anweisungen beachten Sie besonders bei späterer Montage und/oder Aufstellung des Produktes nachsehen.

1. Die Montage und die Aufstellung des Produktes dürfen ausschließlich von erfahrenem Fachpersonal ausgeführt werden. **Vorsicht:** sich nach der Montage immer vergewissern, dass die aufgestellte Struktur ihren Verwendungszwecken und/oder dem Benutzerkreis entspricht. Ist ist aber dabei nicht zu vergessen, daß der Gebrauch dieser Produkte Kindern untersagt ist.
2. Vor jeglicher Montage die Oberfläche, an der das Produkt montiert werden soll, auf ihre Tragfähigkeit prüfen und passende Befestigungsmittel welche die erzeugten Kräfte aushalten können je nach Art der Oberfläche benutzen. **Vorsicht:** die Bodenfläche immer waagrecht, flach, steif und unverformbar sein.
3. Wichtig: bestehen Zweifel über die Einbaumodalitäten und/oder über die Tragfähigkeit der betroffenen Oberfläche, Produkt nicht aufstellen.
4. Für die Installation von **codd.7S60L120, 7S60L120/D** (7S60L120/4, 7S60L120/D4) und **codd.7S90L160, 7S90L160/D** (7S90L160/4, 7S90L160/D4) lesen Sie bitte sorgfältig die Anweisungen im Scheinwerfer
5. **Zur Reinigung der Akustikpaneele (a)** darf nur Schaumreiniger verwendet werden, wobei die Anleitung auf dem gewählten Produkt genau zu befolgen ist.
6. Für weitere Angaben über die Aufstellungsmodalitäten wenden Sie sich bitte an Ihren Wiederverkäufer. Für alle Anlagen, die nicht aufgeführt sind, kontaktieren Sie bitte vor dem Einbau den Fachhandelspartner.
7. Kontrollieren Sie periodisch die mechanische Befestigung.



AKOESTIEKBOETIEK



Deze informatie is afkomstig van de website van AkoestiekBoetiek.nl.

Voor vragen, toelichting en meer informatie kunt u contact opnemen met:

AkoestiekBoetiek

Modem 20b

7741 MJ Coevorden

T +31 (0)85-077 3688

E info@akoestiekboetiek.nl

W www.akoestiekboetiek.nl