



MONTAGE FLOAT

AKOESTIEKBOETIEK



MOD. 567/ L0



Caimi
BREVETTI

FLOAT

Alberto e Francesco Meda

- Elemento fonoassorbente
- Sound absorbing element
- Elemente phono-absorbant
- Elemento fonoabsorbente
- Schallabsorptionselement

* (xx = variante colore, colour alternative, variante couleur, variante color, Farbe Variante)

**ISTRUZIONI DI MONTAGGIO
ASSEMBLY INSTRUCTIONS
INSTRUCTIONS DE MONTAGE
INSTRUCCIONES DE MONTAJE
MONTAGEANLEITUNGEN**

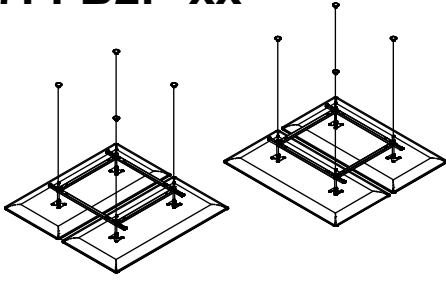
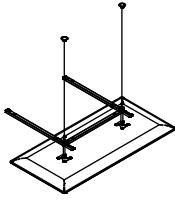
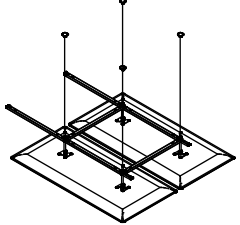
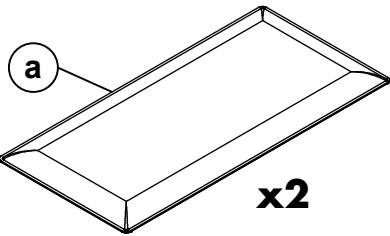
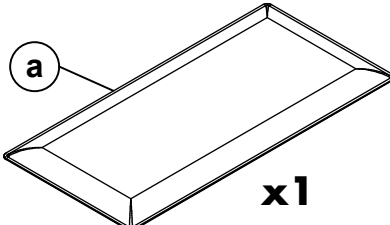
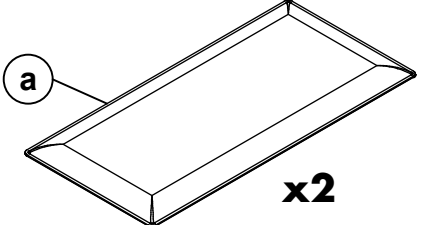
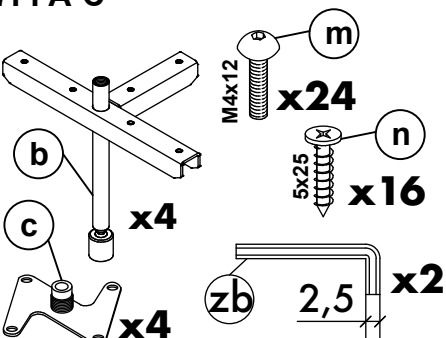
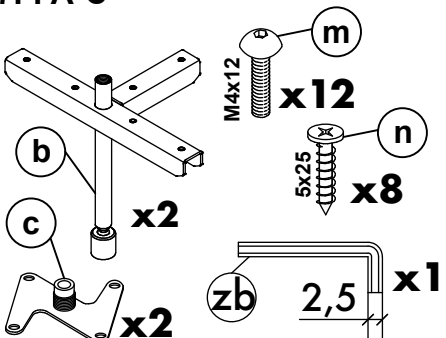
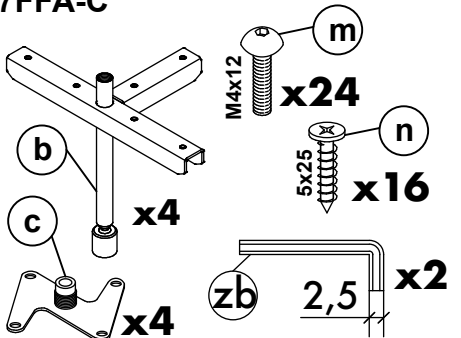
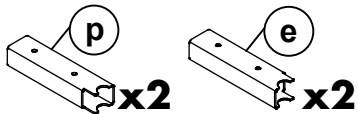
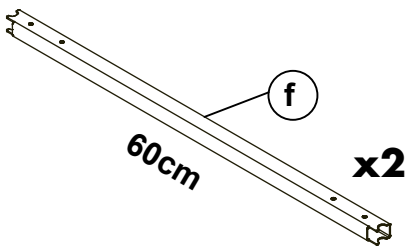
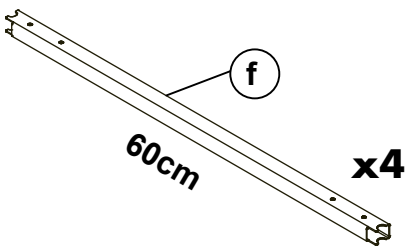
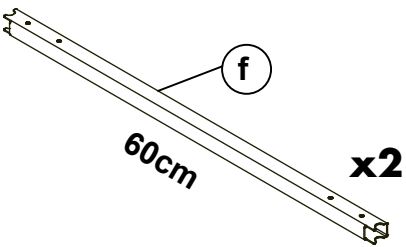
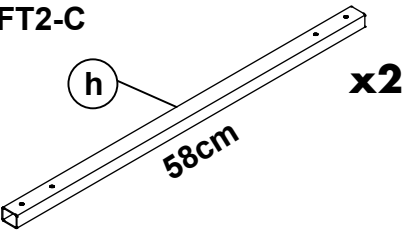
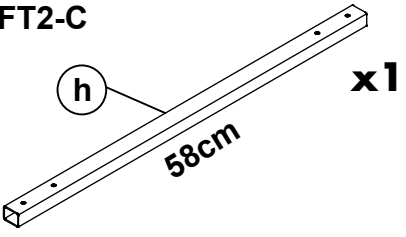
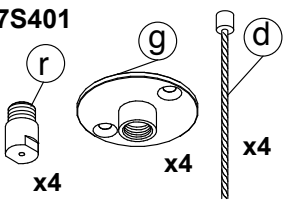
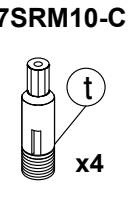
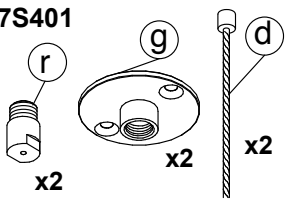
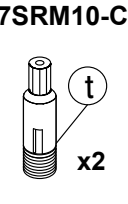
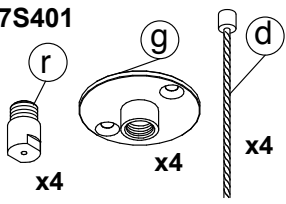
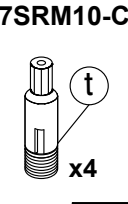
7FFB2P-xx* 		7FFS1P- xx* 		7FFS2P- xx* 	
7FF126-xx* 		7FF126-xx* 		7FF126-xx* 	
7FFA-C 		7FFA-C 		7FFA-C 	
7FFT3-C 		7FFT1-C 		7FFT1-C 	
7FFT1-C 		7FFT2-C 		7FFT2-C 	
7S401 		7SRM10-C 		7S401 	
7SRM10-C 		7S401 		7SRM10-C 	

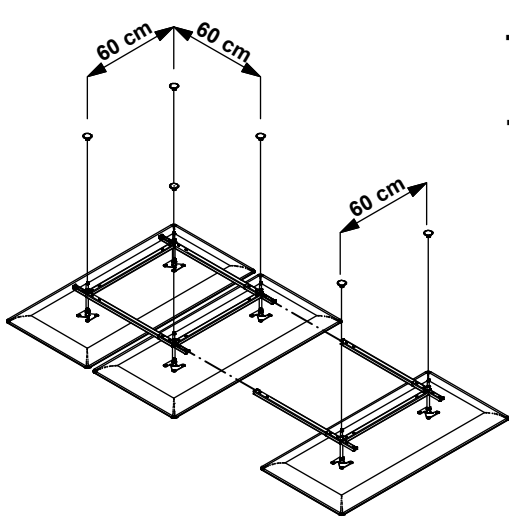
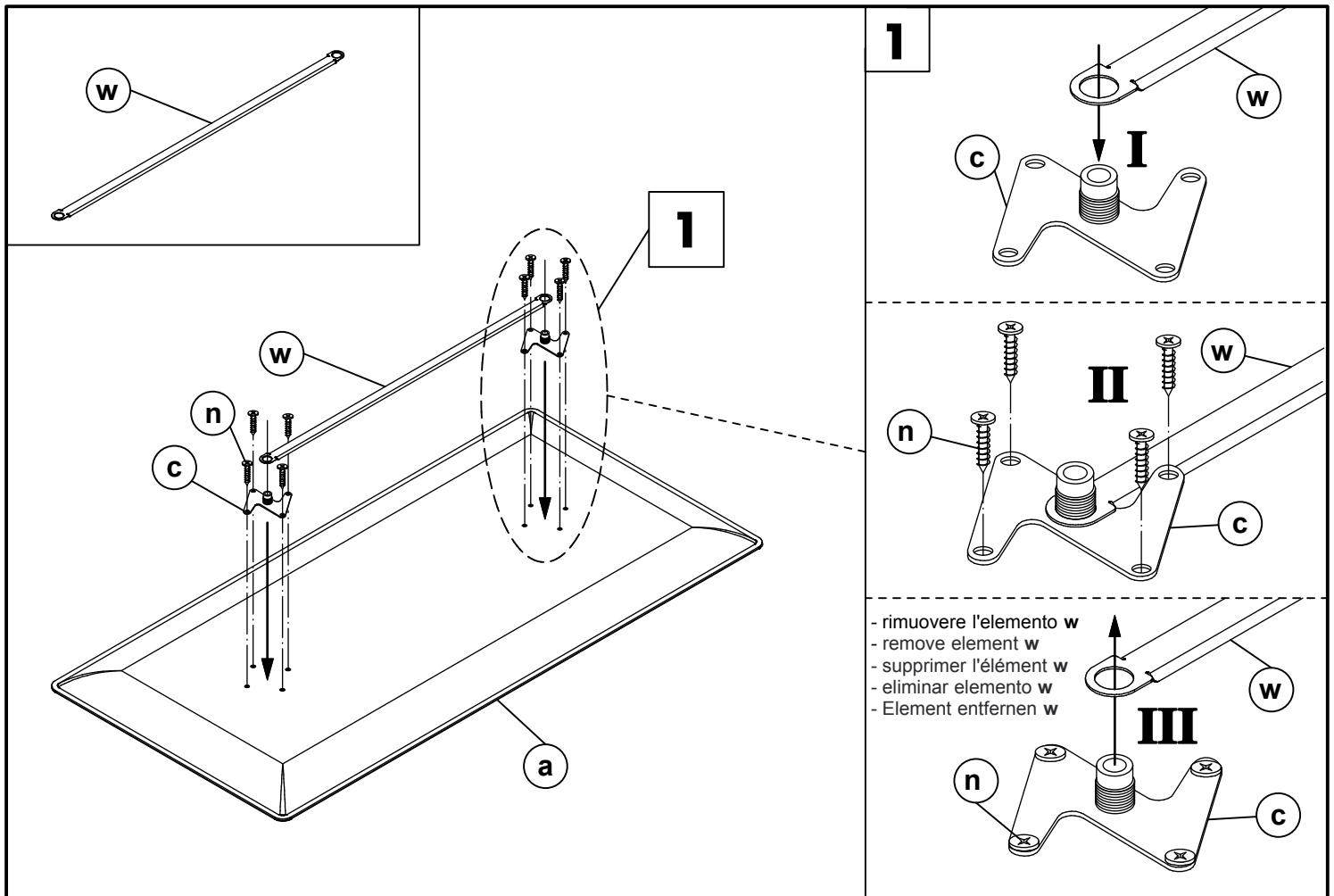

7FFB2P-xx*
+
7FFS1P-xx*

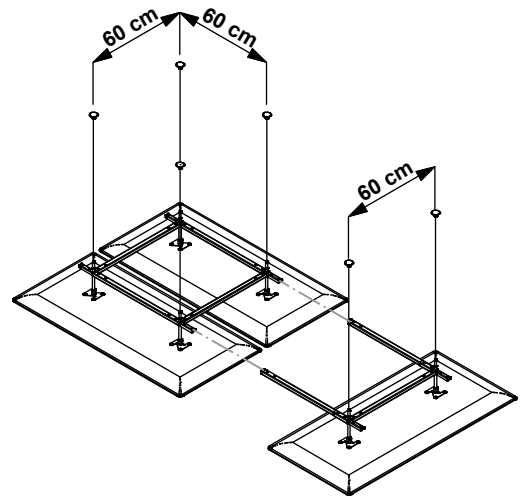

7FFB2P-xx*
+
7FFS2P-xx*

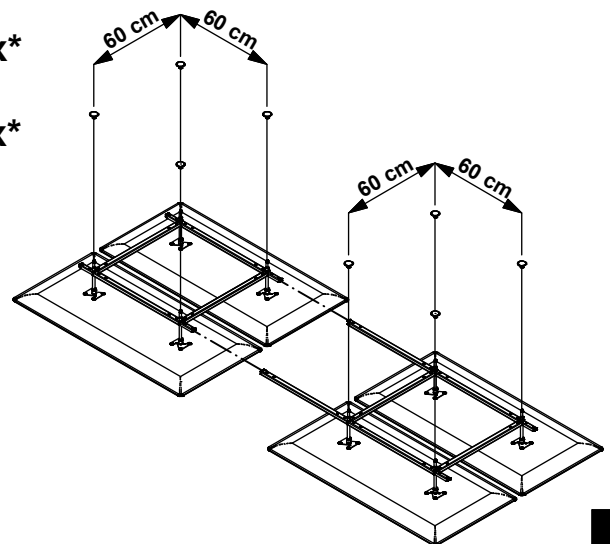
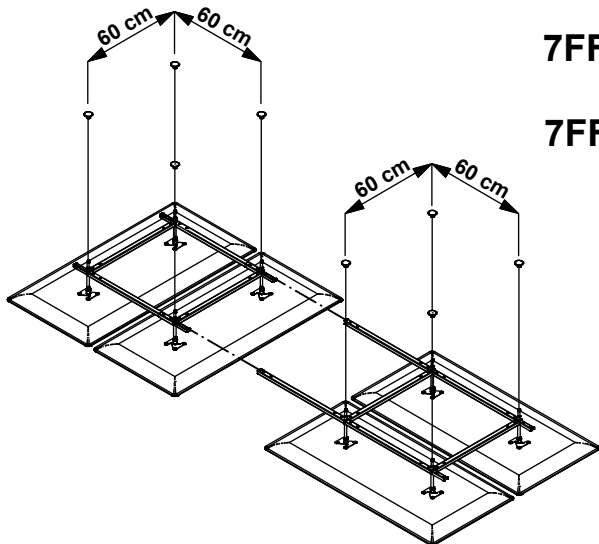

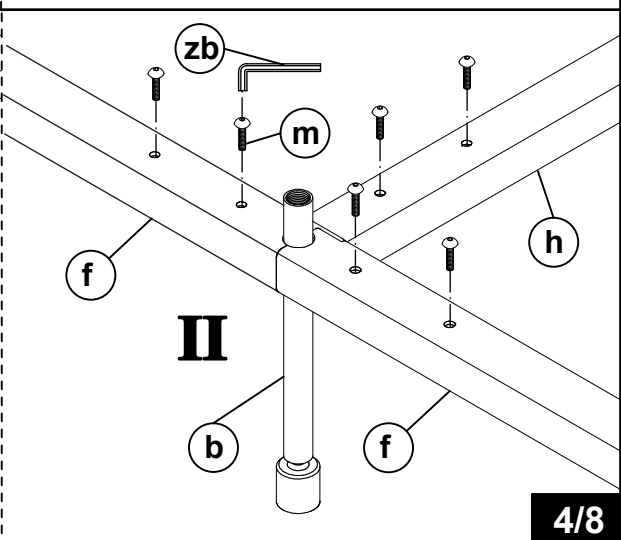
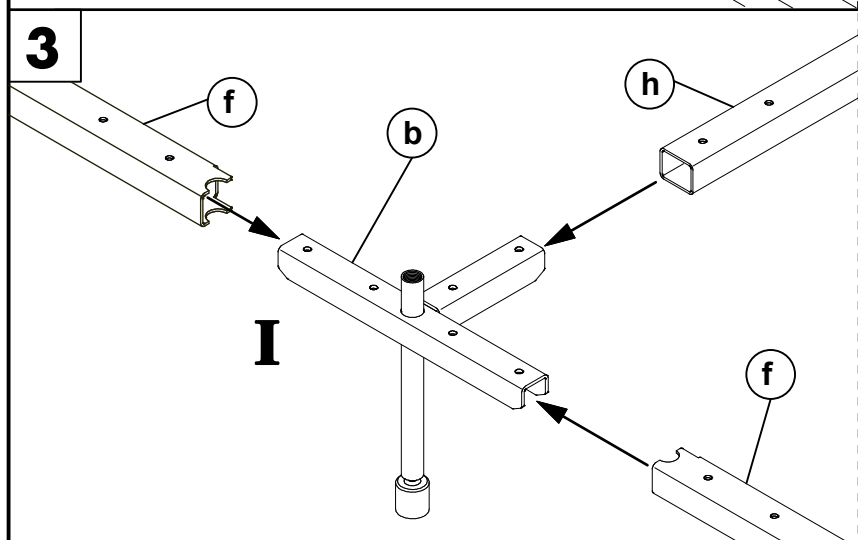
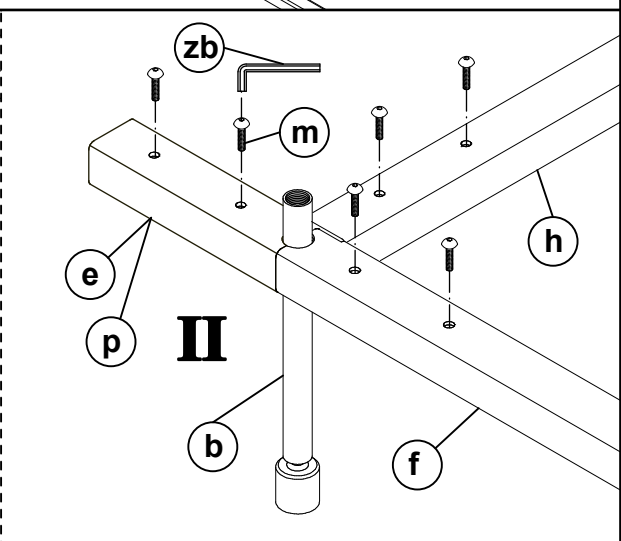
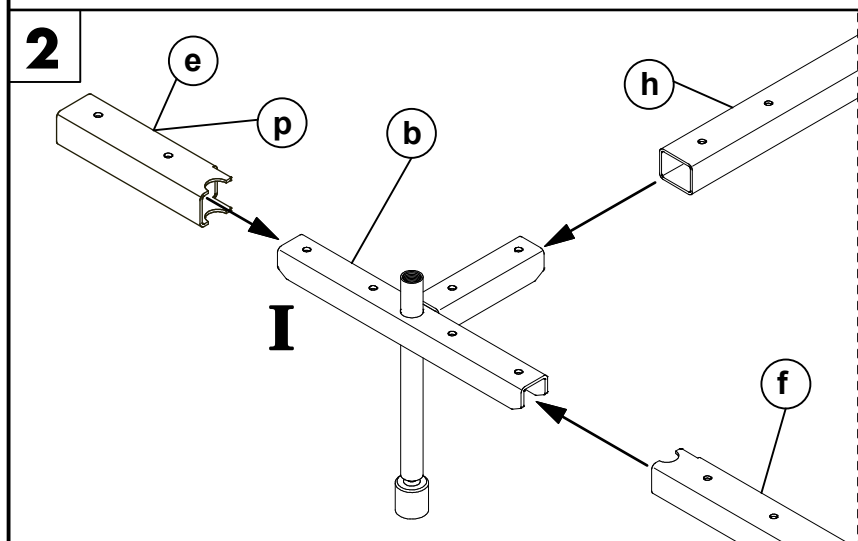
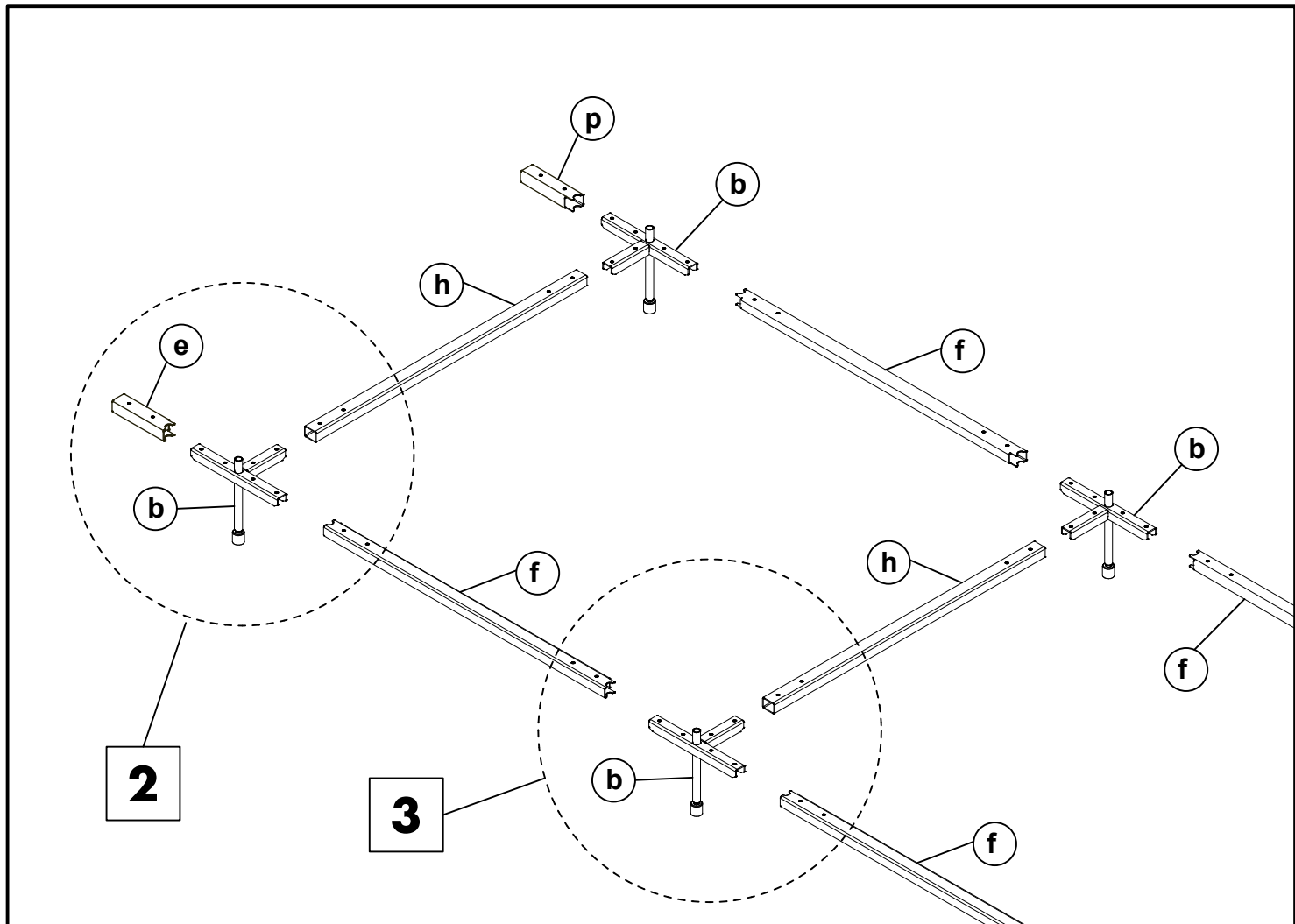

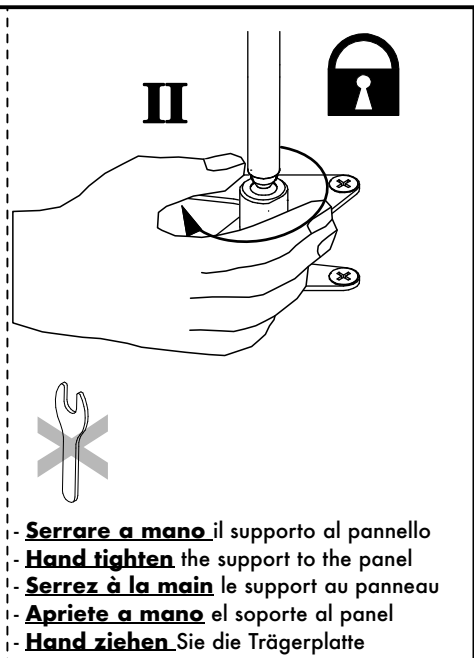
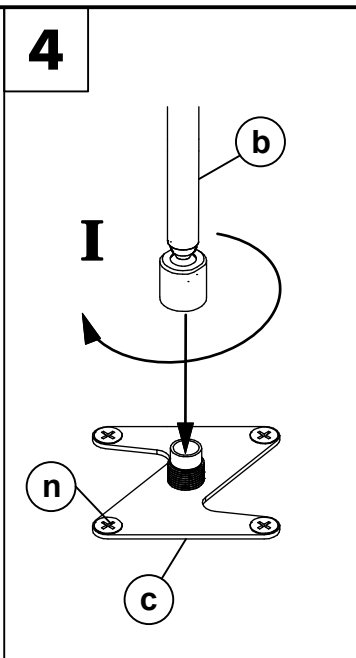
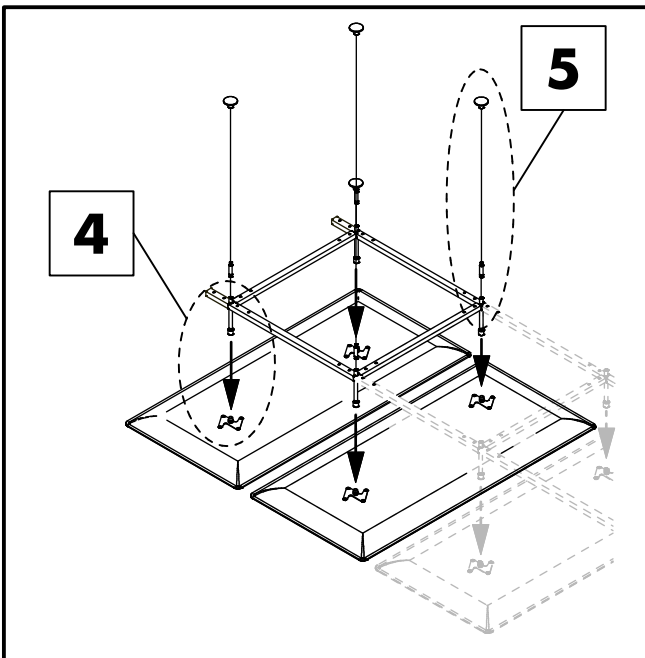

- **Serrare a mano** il supporto al pannello
- **Hand tighten** the support to the panel
- **Serrez à la main** le support au panneau
- **Apriete a mano** el soporte al panel
- **Hand ziehen** Sie die Trägerplatte

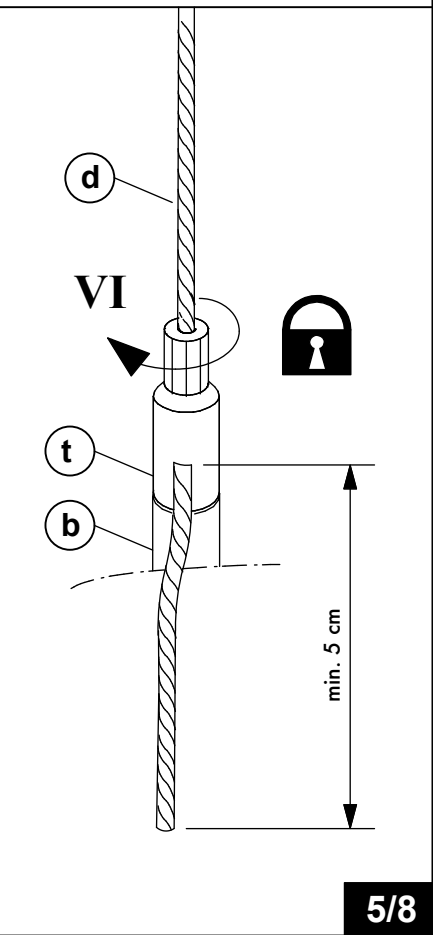
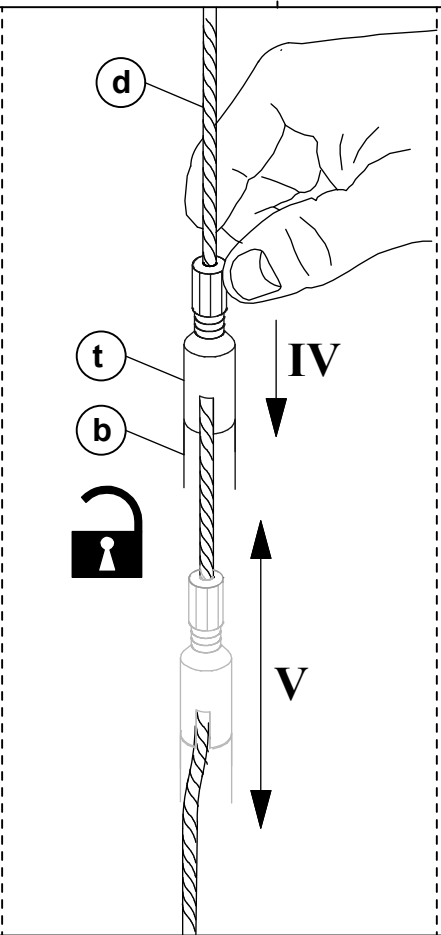
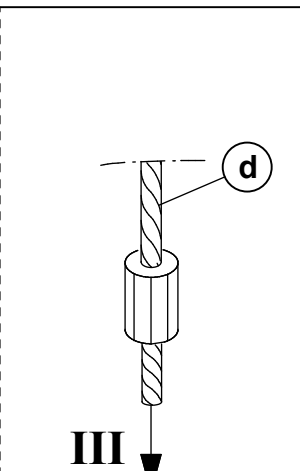
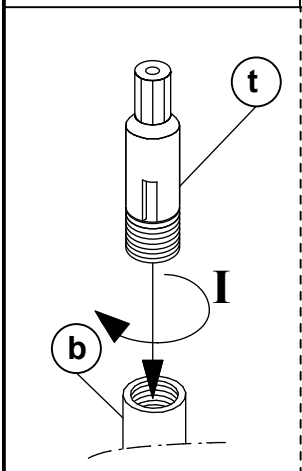
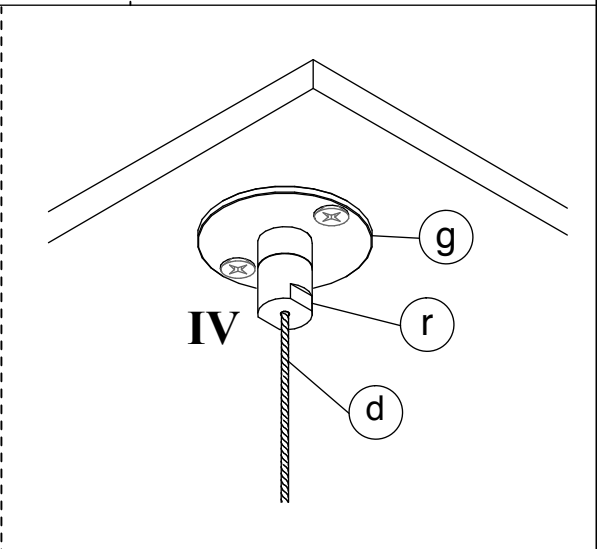
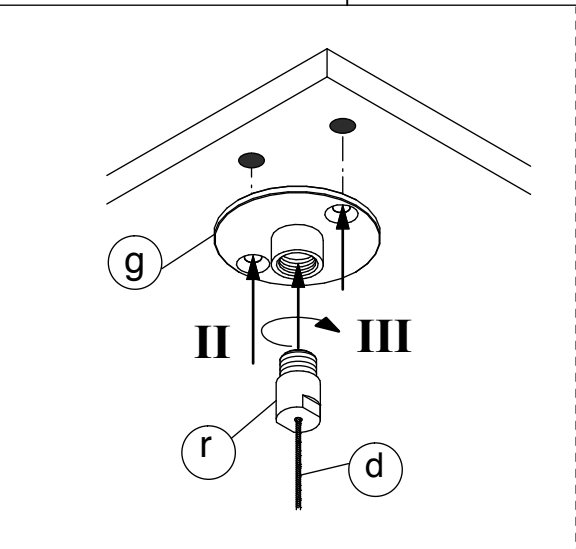
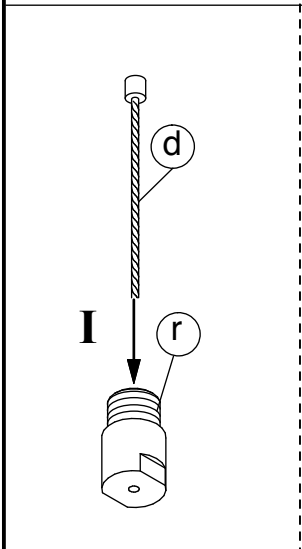

7FFC-C

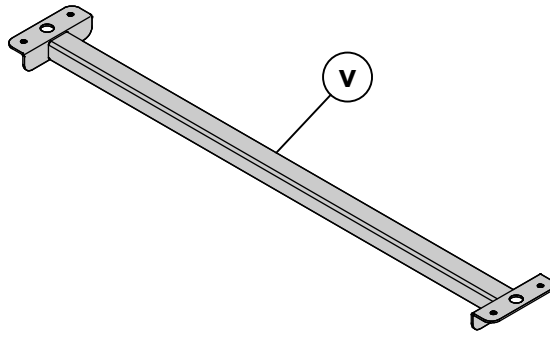

x1

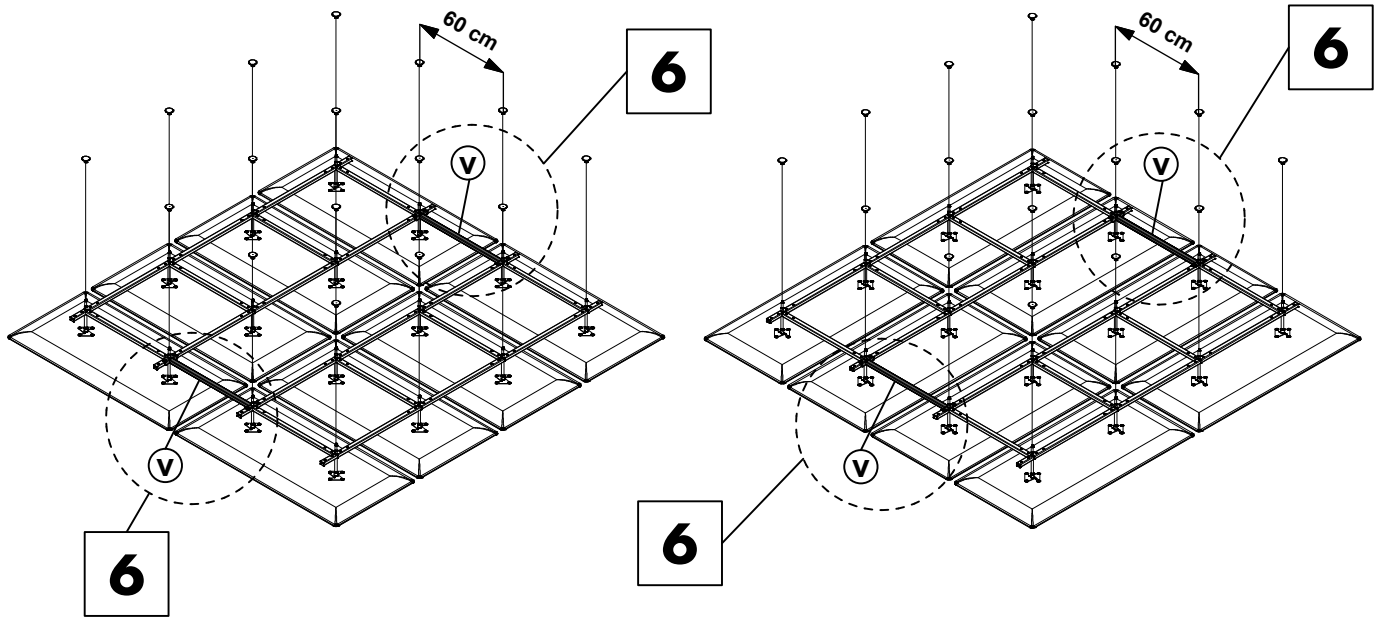

- utilizzare il distanziale (v) ogni 3 o 4 pannelli
- use the spacer (v) every 3 or 4 panels
- utiliser l'entretoise (v) tous les 3 ou 4 panneaux
- utilizar el espaciador (v) cada 3 o 4 paneles
- Verwenden Sie den Abstandshalter (v) alle 3 oder 4 Platten

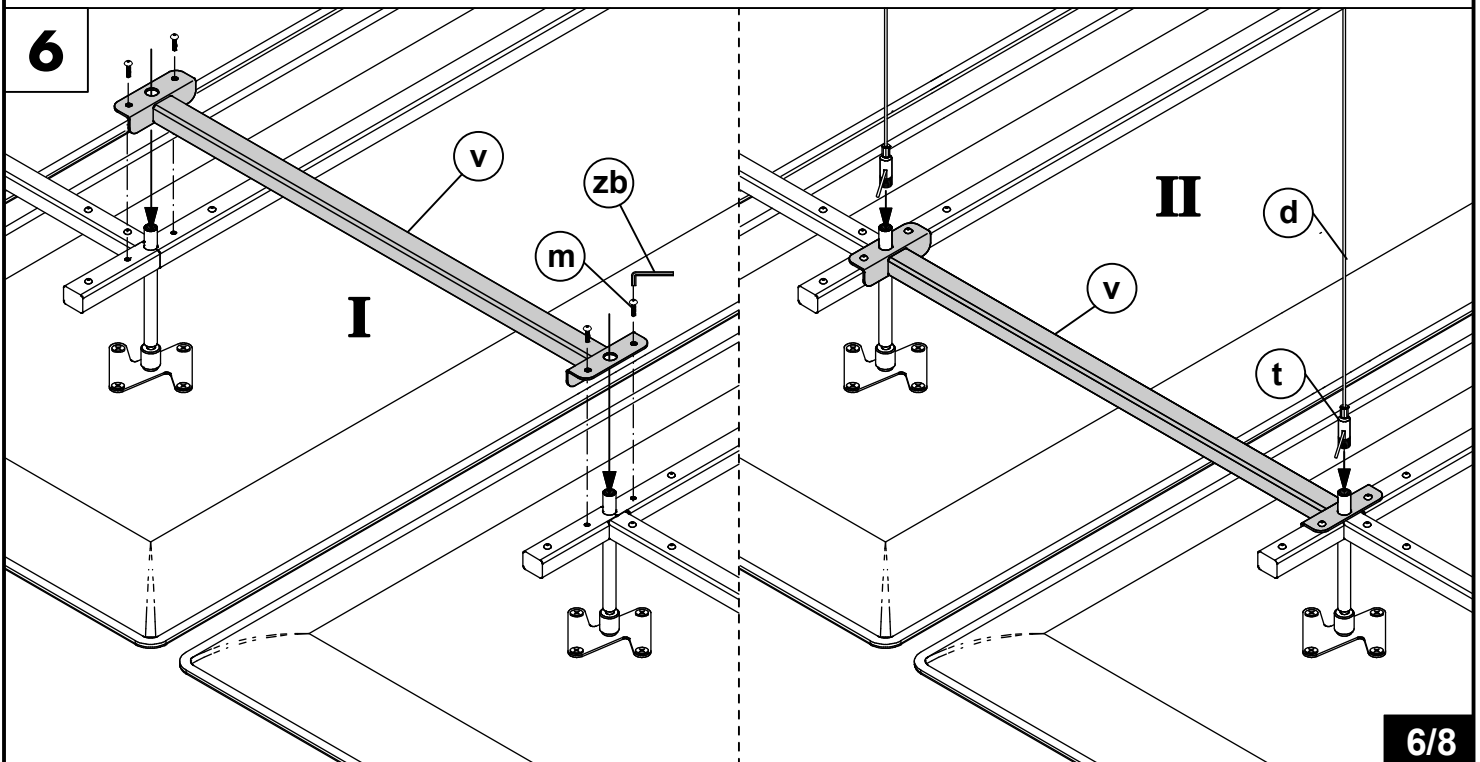

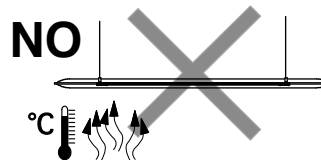
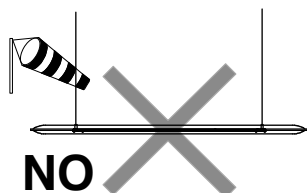
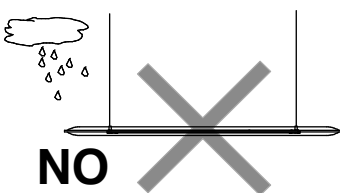
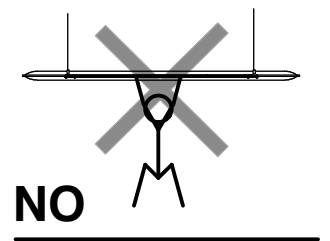
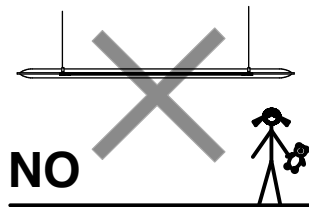
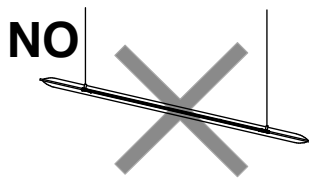
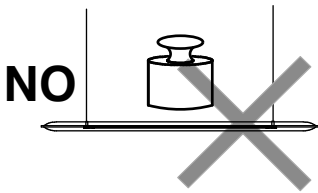
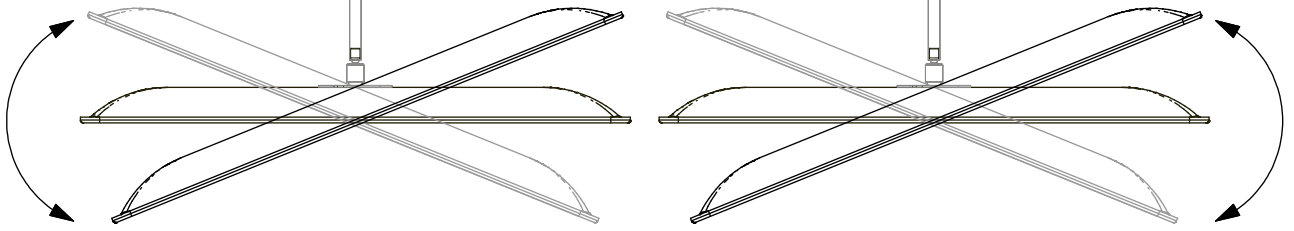

- tenere lontano da fonti di calore
- keep away from heat sources
- tenir loin de sources de chaleur
- mantener alejado de fuentes de calor
- Von Wärmequellen fernhalten

AVVERTENZE!

prima di procedere al montaggio ed all'installazione del prodotto leggere attentamente le avvertenze di seguito riportate, prestando particolare attenzione ai disegni esplicativi riportati nelle istruzioni per il montaggio. Consultare queste avvertenze ad ogni successivo montaggio e/o installazione del prodotto.

1. Il montaggio e l'installazione del prodotto deve essere effettuato esclusivamente da personale tecnico competente. Attenzione: ultimato il montaggio verificare sempre che la struttura realizzata sia idonea al tipo di utenza e/o di utilizzo a cui è destinata. I prodotti non sono comunque idonei all'uso da parte di bambini.
2. Prima di procedere all'installazione è necessario verificare la portanza della superficie su cui verrà collocato il prodotto. Attenzione: la superficie deve comunque essere orizzontale, piana, rigida e indeformabile.
3. Attenzione: in caso di dubbi sulle modalità di installazione e/o sulla portanza della superficie su cui verrà collocato il prodotto non procedere alla installazione del prodotto.
4. **Per la pulizia del pannello** utilizzare esclusivamente un prodotto smacchiatore a secco seguendo attentamente le istruzioni riportate sul prodotto utilizzato.
5. Non utilizzare detersivi **per pulire le parti non in tessuto**. Pulire esclusivamente con panno inumidito d'acqua.
6. Per ulteriori informazioni sulle modalità di installazione del prodotto contattare il rivenditore. Per i casi non contemplati contattare il rivenditore.

NOTE!

Prior to assembling and installing the unit please read the following notes carefully. Pay particular attention to the drawings in the assembly instructions. Please consult these notes every time the product is assembled and/or installed.

1. The product must only be assembled and installed by competent fitters. Warning: once the product has been assembled always check that the structure is suitable for the type of application and/or use to which it will be put. These products are not suitable for use by children.
2. Prior to installation check the load bearing capacity of the surface on which the product is to be fitted. Warning: the surface must be horizontal, flat, rigid and non-deformable
3. Warning: if you have any doubts concerning how to install the product and/or the load bearing capacity of the surface on which it will be fitted, do not fit it.
4. **To clean the panel** use only a dry stain removal, carefully following the instructions on the product used.
5. **Do not use detergents to clean the parts that are not in textile fabric.** Use only a cloth damp with water.
6. For further information on how to install the product, please contact your dealer. For any use different from the ones here shown please contact the dealer.

MISES EN GARDE!

Avant de procéder au montage et à l'installation du produit, lire attentivement les mises en garde ci-dessous présentées, en faisant particulièrement attention aux dessins explicatifs rapportées dans les instructions de montage. Consulter ces mises en garde lors de chaque montage successif et/ou installation du produit.

1. Le montage et l'installation du produit doivent exclusivement être effectués par un personnel technique compétent. Attention: au terme du montage, toujours vérifier si la structure réalisée est appropriée au type d'usagers et/ou d'utilisation auxquels elle est destinée. Les produits ne sont pas destinés aux enfants.
2. Avant de procéder à l'installation, il est nécessaire de vérifier la capacité de charge de la surface sur laquelle le produit sera installé. Attention: la surface doit être horizontale, plane, rigide et indeformable.
3. Attention: en cas de doute sur les modalités d'installation et/ou sur la capacité de charge de la surface sur laquelle le produit sera installé, ne pas monter le produit.
4. **Pour le nettoyage du panneau** utiliser seulement un détachant à sec en suivant soigneusement les instructions sur le produit utilisé.
5. **Ne pas utiliser de détergents pour nettoyer les pièces qui ne sont pas en tissu.** Nettoyer seulement avec un chiffon humidifié avec de l'eau.
6. Pour toute information complémentaire sur les modalités d'installation, contacter le revendeur. Pour emploi différent par rapport à ceux indiqués ici nous vous prions de contacter le revendeur.

¡ADVERTENCIAS!

Antes de realizar el montaje y la instalación del producto leer atentamente las advertencias que se indican a continuación, prestando especial atención a los dibujos y a las instrucciones para el montaje. Consultar estas advertencias cada vez que se monte y/o instale el producto.

1. El montaje y la instalación del producto debe efectuarlo exclusivamente personal técnico competente. Atención: una vez acabado el montaje, hay que comprobar siempre que la estructura realizada sea apta para el tipo de servicio y/o uso al que se va a destinar. Los productos no son aptos para niños.
2. Antes de realizar la instalación es necesario controlar la capacidad de carga de la superficie en la que se colocará el producto. Atención: la superficie debe en cualquier caso ser horizontal, plana, rígida e indeformable.
3. Atención: en caso de duda sobre las modalidades de instalación y/o sobre la capacidad de carga de la superficie en la que se vaya a colocar el producto, éste no deberá instalarse.
4. **Para la limpieza del panel** utilizar exclusivamente un producto quitamanchas en seco, siguiendo atentamente las instrucciones que aparecen sobre el producto utilizado.
5. **No utilizar detergentes para las partes que no son tejidos.** Usar solamente con un tarpo humedecido con agua.
6. Para más información sobre las modalidades de instalación del producto, ponerse en contacto con el vendedor. Para cualquier otra utilización por favor consulte con su distribuidor.

WICHTIG!

Vor der Montage und der Aufstellung des Produktes folgende Anleitungen sorgfältig lesen und dabei die Einbauzeichnungen, die in den Montageanleitungen zu finden sind, genau beachten. Die vorliegenden Anweisungen bei jeglicher späterer Montage und/oder Aufstellung des Produktes nachsehen.

1. Die Montage und die Aufstellung des Produktes dürfen ausschließlich von erfahrenem Fachpersonal ausgeführt werden. Vorsicht: sich nach der Montage immer vergewissern, dass die aufgestellte Struktur ihren Verwendungszwecken und/oder dem Benutzerkreis entspricht. Es ist aber dabei nicht zu vergessen, daß der Gebrauch dieser Produkte Kindern untersagt ist.
2. Vor jeglicher Montage die Oberfläche, an der das Produkt montiert werden soll. Vorsicht: die Oberfläche muss auf jeden Fall waagrecht, eben, starr und unverformbar sein.
3. Wichtig: bestehen Zweifel über die Einbaumodalitäten und /oder über die Tragfähigkeit der betroffenen Oberfläche, Produkt nicht aufstellen.
4. **Zur Reinigung der Akustikpaneele** darf nur Schaumreiniger verwendet werden, wobei die Anleitung auf dem gewählten Produkt genau zu befolgen ist.
5. **No utilizar detergentes para las partes que no son tejidos.** Usar solamente con un tarpo humedecido con agua.
6. Für weitere Angaben über die Aufstellungsmodalitäten wenden Sie sich bitte an Ihren Wiederverkäufer. Für alle Anlagen, die nicht aufgeführt sind, kontaktieren Sie bitte vor dem Einbau den Fachhandelspartner.



AKOESTIEKBOETIEK



Deze informatie is afkomstig van de website van AkoestiekBoetiek.nl.

Voor vragen, toelichting en meer informatie kunt u contact opnemen met:

AkoestiekBoetiek

Modem 20b

7741 MJ Coevorden

T +31 (0)85-077 3688

E info@akoestiekboetiek.nl

W www.akoestiekboetiek.nl